

TECHNICAL MANUAL

OPERATOR'S, ORGANIZATIONAL,
DIRECT SUPPORT AND GENERAL SUPPORT
MAINTENANCE MANUAL
FOR
OPERATIONAL UNIT, TRANSPORTABLE SYSTEM

This publication is not available through AG publications. Requisition from: Commander, USASA, Materiel Supply Command, ATTN: IAMNMP/E, Vint Hill Farms Station, Warrenton, Virginia 22186.

HEADQUARTERS, DEPARTMENT OF THE ARMY

FEBRUARY 1977

WARNING

DEATH or SERIOUS INJURY may result from hazards in this equipment unless the proper safety measures are observed.

READ and OBSERVE the referenced warnings contained herein and in the technical manuals provided for the system components.

**OPERATOR'S, ORGANIZATIONAL,
DIRECT SUPPORT, AND GENERAL SUPPORT
MAINTENANCE MANUAL
FOR
OPERATIONAL UNIT, TRANSPORTABLE SYSTEM**

This publication is not available through AG publications. Requisition from: Commander, USASA, Materiel Supply Command, ATTN: IAMNMP/E, Vint Hill Farms Station, Warrenton, Virginia 22186.

NOTICE

As contained in this publication, the words he, his and him are intended to include both the masculine and the feminine genders. Any exceptions to this are so noted.

INSERT LATEST CHANGED PAGES, DESTROY SUPERSEDED PAGES.

LIST OF EFFECTIVE PAGES

NOTE: The portion of the text affected by the changes is indicated by a vertical line in the outer margins of the page.

Dates of issue for original and changed pages are:

TOTAL NUMBER OF PAGES IN THIS PUBLICATION IS 42 CONSISTING OF THE FOLLOWING:

| Page No. | *Change No. | Page No. | *Change No. |
|----------------------------|----------------|-------------------------------|----------------|
| Warning Page | 0 | 3-1/3-2 Blank. | 0 |
| Title Page | 0 | 4-1 and 4-2 | 0 |
| A Page | 0 | 5-1 through 5-3/5-4 Blank . . | 0 |
| Record of Changes | | 6-1/6-2 Blank | 0 |
| (Rreverse Blank) | 0 | 7-1/7-2 Blank | 0 |
| i and ii | 0 | Appendix A-1 and A 2 | 0 |
| 1-1 through 1-10 | 0 | Appendix B-1 through B-6 . | 0 |
| 2-1 through 2-10 | 0 | | |

* Zero in this column indicates an original page.

RECORD OF CHANGES

| Change No. | Date | Title or Brief Description | Entered By |
|------------|------|----------------------------|------------|
| | | | |

TECHNICAL MANUAL

HEADQUARTERS
DEPARTMENT OF THE ARMY
WASHINGTON, DC

Operator's, Organizational,
Direct Support, and General Support
Maintenance Manual
For
Operational Unit, Transportable System

| | Page |
|--|------|
| CHAPTER 1. INTRODUCTION | |
| Section I. General | 1-1 |
| Section II. Description and Data | 1-2 |
| CHAPTER 2. SERVICE UPON RECEIPT AND INSTALLATION | |
| Section I. Preparation | 2-1 |
| Section II. Service Upon Receipt of Equipment | 2-1 |
| Section III. Installation | 2-2 |
| CHAPTER 3. OPERATING INSTRUCTIONS | 3-1 |
| CHAPTER 4. OPERATOR/CREW MAINTENANCE INSTRUCTIONS | |
| Section I. Tools and Equipment | 4-1 |
| Section II. Lubrication Instructions | 4-1 |
| Section III. Preventive Maintenance Checks and Services | 4-1 |
| Section IV. Troubleshooting | 4-2 |
| CHAPTER 5. ORGANIZATIONAL MAINTENANCE INSTRUCTIONS | |
| Section I. Tools and Equipment | 5-1 |
| Section II. Repainting and Refinishing Instructions | 5-1 |
| Section III. Lubrication Instructions | 5-1 |
| Section IV. Preventive Maintenance Checks and Services | 5-1 |
| Section V. Troubleshooting | 5-3 |
| CHAPTER 6. FUNCTIONING OF EQUIPMENT | 6-1 |
| CHAPTER 7. DIRECT SUPPORT AND GENERAL SUPPORT MAINTENANCE INSTRUCTIONS | |
| Section I. General | 7-1 |
| Section II. Tools and Equipment | 7-1 |
| APPENDIX A. REFERENCES | A-1 |
| APPENDIX B. MAINTENANCE ALLOCATION CHART | B-1 |

LIST OF ILLUSTRATIONS

| Figure | Page |
|--|------|
| 1-1. Operational Unit, Transportable System (OUTS) | 1-1 |
| 1-2. Operations and Electrical Facility, Mobile, AN/MSA-34 Configuration | 1-2 |
| 1-3. OUTS Baseline Configuration | 1-4 |
| 1-4. Power Distribution Subsystem | 1-5 |
| 1-5. Antenna Distribution Subsystem | 1-6 |
| 1-6. Digital Clock Subsystem | 1-8 |
| Intercommunication Subsystem | 1-9 |
| 1-8. Emergency Lighting Subsystem | 1-10 |
| 2-1. Installation of a Seven-AN/MSA-34 Unit Complex | 2-3 |
| 2-2. Shelter Walkway Interconnections | 2-5 |
| 3-1. Emergency Lighting Power Source Assembly | 3-1 |
| 6-1. Emergency Lighting Block Diagram | 6-1 |

LIST OF TABLES

| Table | Page |
|--|------|
| 1-1. Units Comprising an Operable OUTS | 1-2 |
| 2-1. Antenna Distribution Interconnections | 2-8 |
| 2-2. Antenna Input Connections | 2-8 |
| 2-3. Digital Clock Interconnections | 2-9 |
| 2-4. Intercommunication Subsystem Interconnections | 2-9 |
| 2-5. Intercommunication Facilities in Shelters | 2-9 |
| 2-6. Emergency Lighting Subsystem Interconnections | 2-10 |
| 3-1. Emergency Lighting Controls and Indicators | 3-1 |
| 4-1. Operator/Crew Daily Preventive Maintenance | 4-1 |
| 5-1. Organizational Preventive Maintenance Checks and Services | 5-1 |
| 5-2. Emergency Lighting Troubleshooting Chart | 5-3 |

CHAPTER 1

INTRODUCTION

Section I. GENERAL

1-1 SCOPE. This manual describes the Operational Unit, Transportable System (OUTS) (fig. 1-1) and provides instructions for operator's, organizational, direct support, and general support maintenance of the system.

1-2 MAINTENANCE FORMS AND RECORDS.

a. Department of the Army forms and records used for equipment maintenance will be those prescribed by TM 38-750.

b. Equipment Improvement Recommendations (EIR) will be prepared using DA Form 2407, Maintenance Request. Instructions for preparing EIR's are provided in TM 38-750, The Army Maintenance Management System. EIR's should be mailed directly to Commander, USASA Materiel Support Command, ATTN: IAMNMP/M, Vint Hill Farms Station, Warrenton, Virginia 22186. A reply will be furnished directly to you.

1-3 EQUIPMENT SERVICEABILITY CRITERIA (ESC). OUTS is not covered by an ESC technical manual. See

Appendix A for listing of technical manuals on individual components of the OUTS.

1-4 DESTRUCTION OF ARMY MATERIEL TO PREVENT ENEMY USE. Destruction of the OUTS will be in accordance with instructions prescribed by TM 750-244-2 and as supplemented by instructions in individual technical manuals covering specific items of equipment in the subsystems.

1-5 ADMINISTRATIVE STORAGE. Administrative storage will be in accordance with instructions prescribed in TM 740-90-1.

1-6 REPORTING OF ERRORS. The reporting of errors, omissions, and recommendations for improving this publication by the individual user is encouraged. Reports should be submitted on DA Form 2028, Recommended Changes to Publications, and forwarded direct to: Commander, USASA Materiel Support Command, ATTN: IAMNMP/E, Vint Hill Farms Station, Warrenton, Virginia 22186.

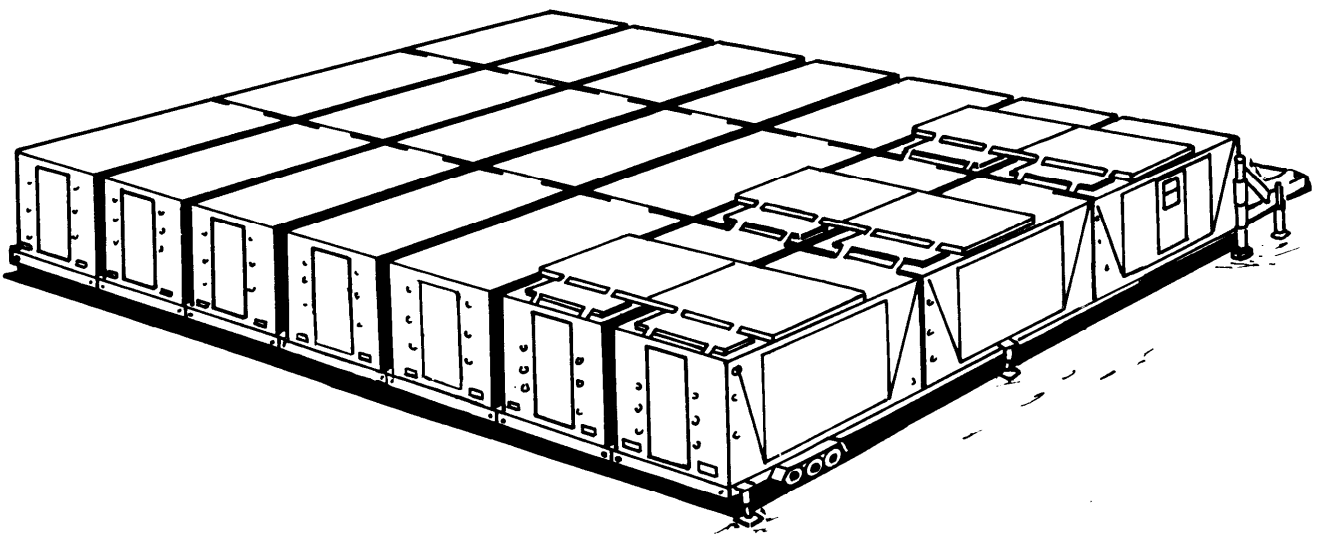

Figure 1-1. Operational Unit, Transportable System (OUTS)

Section II. DESCRIPTION AND DATA

1-7 PURPOSE AND USE. OUTS operates as a large communication complex. It is designed to receive, record, identify, and analyze radio frequency information received in the form of CW, voice, teletype, and facsimile transmissions within a frequency range of 0.5 to 32 MHz. The equipment and working space for all of these operations, together with their control, administration, and maintenance equipments, are contained in 21 transportable shelters that are interconnected to give the effect of all operations being under one roof.

1-8 DESCRIPTION

a. General. For mobility, the 21 individual shelters of equipment comprising the OUTS are installed on seven semitrailers, three per trailer. Each trailer is a Semitrailer, Low-Bed, V-398/MSA-34. Each of the 21 shelters, without equipment installed therein for a specific task, is a Shelter, Electrical Equipment, S-389/MSA-34. Each V-398 trailer, with three S-389 shelters mounted thereon, comprises an Operations and Electrical Facility, Mobile, AN/MSA-34, as shown in figure 1-2. Each of the 21 shelters in OUTS has equipment installed therein for a specific task; the equipment, illustrated in figure 1-3, has an official nomenclature detailed in table 1-1 that denotes its function as a facility or central.

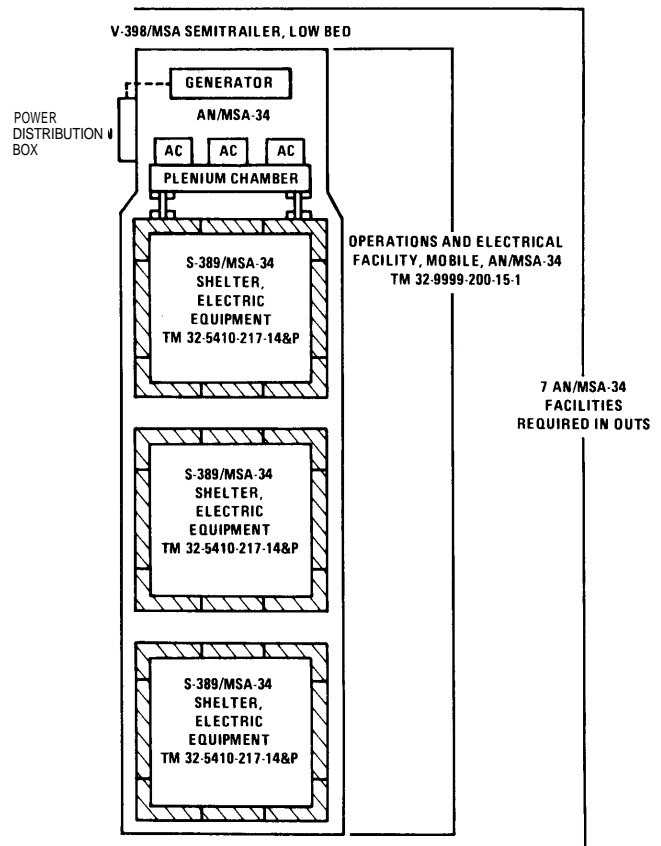

Figure 1-2. Operations and Electrical Facility, Mobile, AN/MSA-34 Configuration

Table 1-1. UNITS COMPRISING AN OPERABLE OUTS

| S-389 Shelter No. | Nomenclature | NSN | Technical Manual |
|-------------------|---|------------------|---|
| 1 | Repair Parts Storage Facility, AN/USM-379 | 5410-00-169-5114 | TM 32-5410-215-14 |
| 2,5 | Radio Maintenance Central, AN/TRM-18 | 4940-00-937-8709 | TM 32-4940-200-14 TM 32-4940-200-15P |
| 3,6,12,15 | Radio Receiver Central, AN/TRR-27 | 5895-00-937-8525 | TM 32-5895-217-14 TM 32-5895-217-15P |
| 4 | Teletype Maintenance Central, AN/TGM-2 | 999940-937-8708 | TM 32-4940-200-14 TM 32-4940-200-15P |
| 7,10 | Teletype Receiving Central, AN/TGR-2 | 5815-00-183-7746 | TM 32-5815-206-14 TM 32-5815-206-15P |
| 8 | Facsimile Receiving Central, AN/TXR-3 | 5815-00-937-8526 | TM 32-5815-205-14 TM 32-5815-205-15P |

Table 1-1. UNITS COMPRISING AN OPERABLE OUTS (Continued)

| S-389 Shelter No. | Nomenclature | NSN | Technical Manual |
|-------------------|---|------------------|---|
| 9,11 | Administrative Control Central, AN/TSQ-79 | 9999-00-937-8707 | TM 32-4940-202-14 TM 32-4940-202-15P |
| 13 | Teletype Receiving Central, AN/TGR-1 | 5815-00-937-8527 | TM 32-5815-206-14 TM 32-5815-206-15P |
| 14,17,20 | Data Analysis Central, AN/TYQ-5 | 5895-00-937-8530 | TM 32-5895-248-14 TM 32-5895-248-15P |
| 16,19 | Communications Central, AN/TSC-75A | | TM 32-5895-006-14 |
| 18 | Operations Control Central, AN/TSQ-78 | 5895-00-937-8528 | TM 32-5895-216-14 TM 32-5895-216-15P |
| 21 | Radio Identification Central, AN/TRX-1 | 5895-00-937-8529 | TM 32-5895-218-14 TM 32-5895-218-15P |
| | Operations and Electrical Facility, Mobile, AN/MSA-34 | 9999-00-995-2747 | TM 32-9999-200-15-1 |

b. Limitations. For maximum performance, each shelter within the OUTS is designed with a place for each equipment and specific locations for all interconnections for each component. No provision has been made for natural lighting from outside the shelters, and only one door is used for entrance and exit of personnel.

c. Subsystems. The OUTS contains five subsystems that are interconnected among the individual shelters and the AN/MSA-34 units, as follows:

(1) Power Distribution Subsystem. The Power Distribution Subsystem (fig. 1-4,) provides 208-V, 60-Hz, 3-phase, 4-wire ac power for all of the usual operations of OUTS.

(a) Each generator set provides ac power to an AN/MSA-34. There is no interconnection of ac power from one AN/MSA-34 to another AN/MSA-34. On each V-398 trailer, the power distribution subsystem consists of the 30-kW generator set mounted on the gooseneck, a power distribution box mounted on the road side of the gooseneck, and the necessary interconnecting cables.

(b) When available, commercial ac power, or an alternate central 200-kW generator set, may be used in lieu of operating the seven 30-kW generator sets. To use the outside power, the cables from the 30-kW generator sets are

disconnected from the AN/MSA-34 power distribution box input terminals. The outside power may be connected to an OUTS power distribution box by seven cables to the seven AN/MSA-34 power distribution boxes as shown by the dotted lines in figure 1-4.

(2) Antenna Distribution Subsystem. The Antenna Distribution Subsystem is shown in figure 1-5.

(a) RF coaxial cables from the 10 receiving antennas input to the OUTS by means of a cable access assembly located on a side shelter wall of the AN/TSQ-78 Operations Control Central, shelter 18. Within the AN/TSQ-78, the antenna inputs are filtered, amplified, power-divided, isolated, and switched by the AN/GRQ-23, RF Switching Set, which performs all RF distribution functions for the OUTS. The AN/GRQ-23 switches any or all of the 10 antenna inputs to any or all of up to 60 receivers. The processed antenna inputs exit the AN/TSQ-78 shelter through the same cable access assembly on the side wall and are fed by cables to various shelters of the OUTS. Selection of antenna inputs is controlled by the individual operators at their positions by means of matrix-control (thumbwheel) switches.

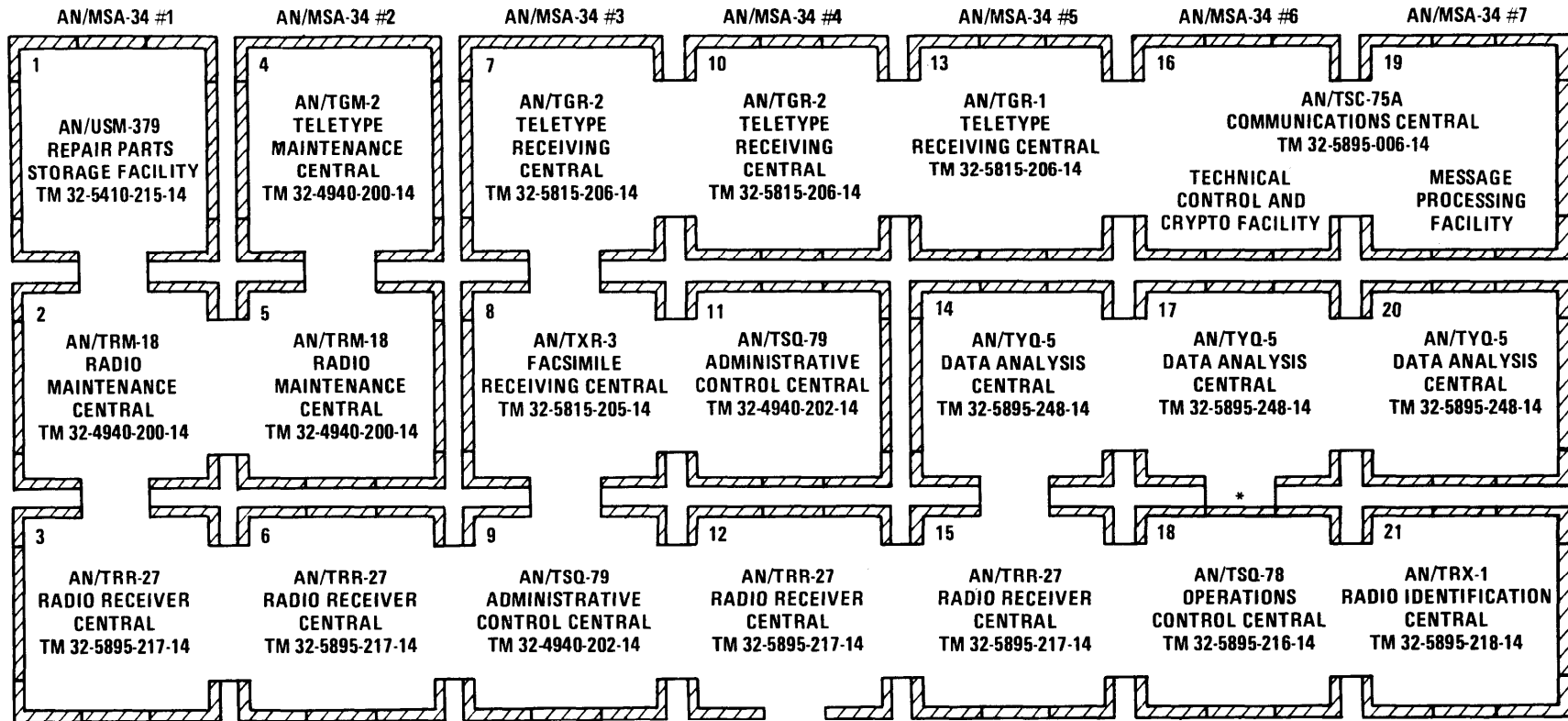

(ENTRANCE)

LEGEND:

1 THROUGH 21 - INDICATE THE 21 S-389/MSA-34 ELECTRICAL EQUIPMENT SHELTERS

*THIS IS NOT A PASSAGEWAY FOR PERSONNEL. WALKWAY AND DOOR PROVIDE ACCESS TO BACKSIDE OF EQUIPMENT IN AN/TSQ-78.

Figure 1-3. OUTS Baseline Configuration

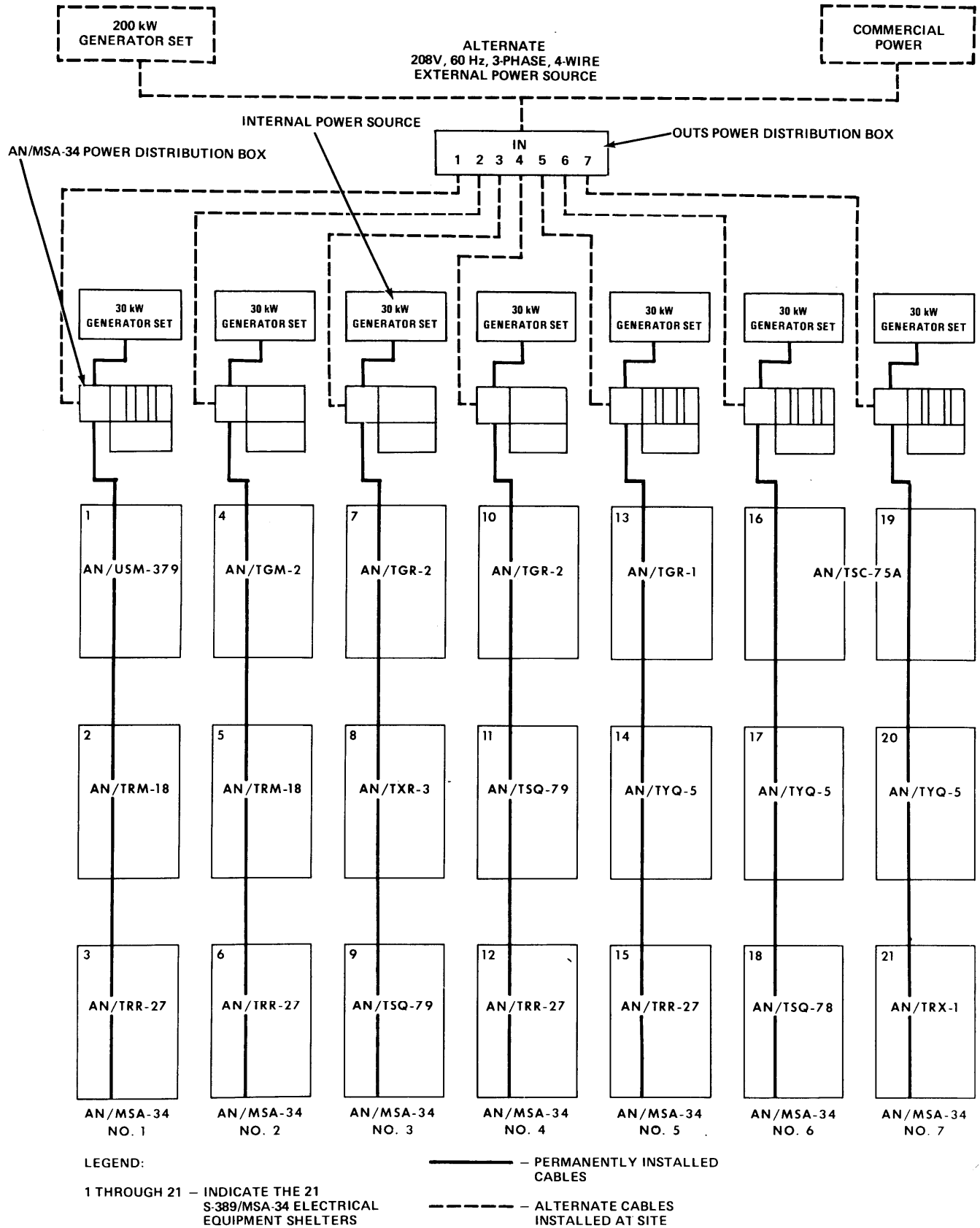

Figure 1-4. Power Distribution Subsystem

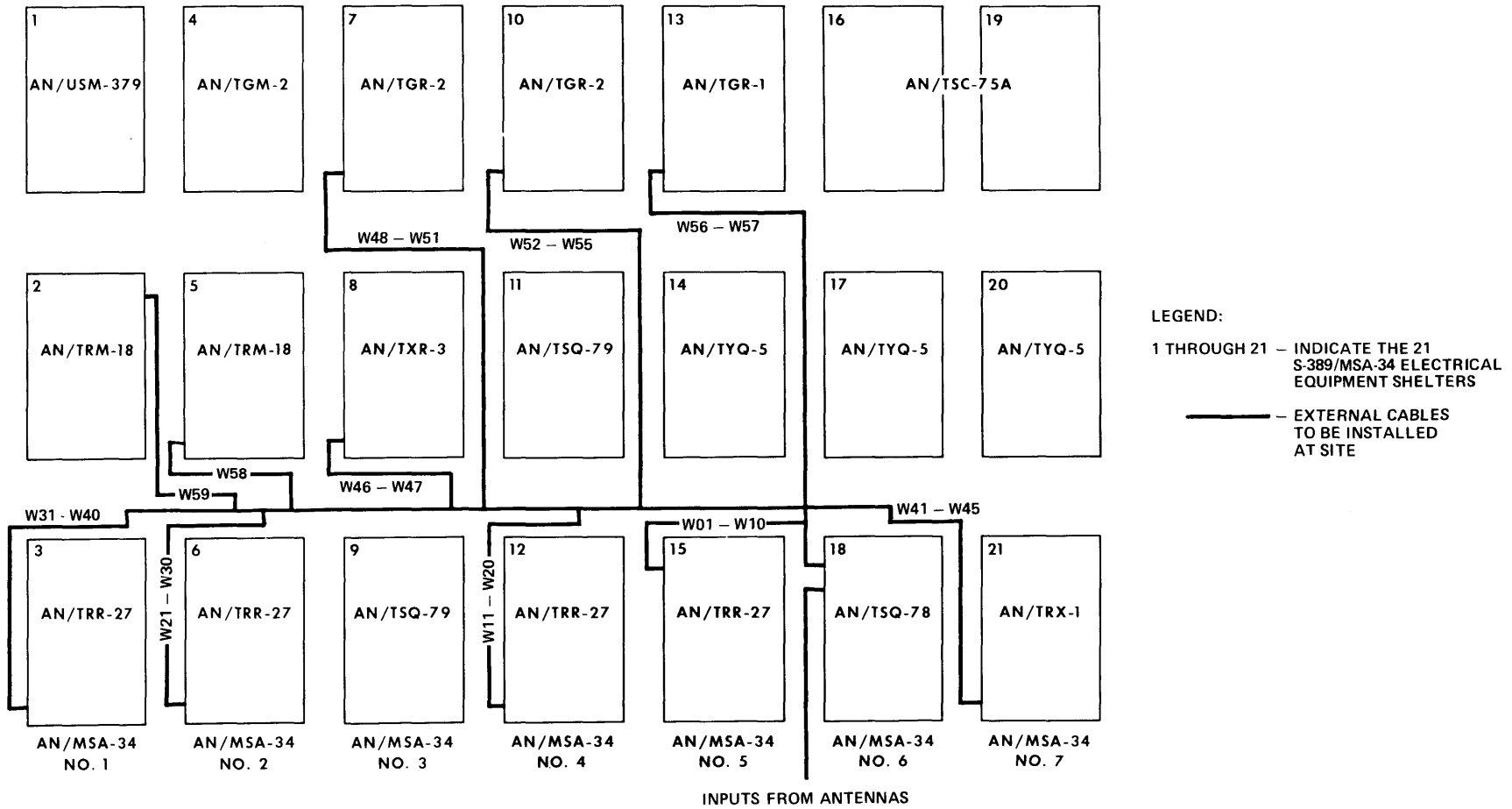

Figure 1-5. Antenna Distribution Subsystem

(b) The antenna equipment required by, but not a part of OOTS is troop-installed and consists of five AN/MRA-17 Antenna Systems. Each AN/MRA-17 is a trailer-mounted, rapidly -erected, high-frequency, log-periodic antenna. Each antenna has two independent outputs: one for horizontally-polarized signals and one for vertically-polarized signals. The outputs may be used simultaneously or individually. The AN/M RA - 17 is covered by TM 32-5985-205-15.

(3) *Digital Clock Subsystem.* The Digital Clock Subsystem (fig. 1-6), Chrono-Log Corporation System No. 67056, has a master digital-display clock. The clock is rack-mounted in the AN/TRM- 18, Radio Maintenance Central, shelter 5. There are 17 remote digital-display clock units interconnected throughout the OOTS. Five of the remote units are ceiling-mounted: two are in the AN/TSQ-79, Administrative Control Centrals, located in shelters 9 and 11; two are in the AN/TYQ-5, Data Analysis Centrals, located in shelters 20 and 14; and one is located in the AN/USM-379, Repair Parts Stowage Facility, shelter 1. The remaining remote units are rack-mounted and are located in shelters 2 through 4, 6 through 8, 10, 12, 13, 15, 18 and 21. The Digital Clock Subsystem provides and digitally displays standard time in the various shelters. The master digital-display clock sends time-signal pulses continuously through interconnecting cables to the 17 remote units located in the various shelters. Detailed information covering the digital-clock equipment is provided in the applicable commercial technical manuals.

(4) *Intercommunication Subsystem.* The Intercommunications Subsystem (fig. 1-7) is designed to provide intercom-, monitor- and recorder-control functions among numerous remote stations, a central switchboard, and a Communication Control Console (CCC). This Intercommunication Subsystem provides for:

(a) Intercommunication one-way, two-way, and conference calls.

(b) Monitoring and control of radio reception at various operator positions.

(c) Monitoring any selected remote station without being detected. Transferring monitoring and control of radio reception from remote station to the AN/TRX - 1, Radio Identification Central, located in shelter 21. Detailed information covering the Intercommunication Subsystem's equipment is contained in Instruction Manual, TM 32-5895-227-14, for Communications Central, AN/MSQ-71, and in TM 32-5895-216-14 for the AN/TSQ-78.

(5) *Emergency Lighting Subsystem.* The Emergency Lighting Subsystem (fig. 1-8) is an automatic, independent lighting system that provides shelter interior lighting for up to 2 hours in the event of loss of ac power. Shelters 5, 7,8, 12, and 14 have 12-V floodlamps connected to nearby cable access assembly connectors on the shelter walls. External cables W-101 to W-105 connect the cable access assembly connectors to the connectors of the emergency power source assembled in the utility storage cabinet under the gooseneck of AN/MSA-34 No. 4. The emergency power-source assembly contains a 100-A hour, 12-V, lead-acid storage battery; an at-powered, 10-A battery charger; a relay switch which connects the battery to the charger when ac power is available, and connects the battery to the lamps when ac power is not available; and an override toggle switch which can be used to disconnect the lamps from the battery when emergency lighting is not needed and ac power is not available. AC power for the battery charger and relay is fed to the emergency lighting system from the ac outlet in shelter 10 on AN/MSA-34 No. 4 by cable W-100.

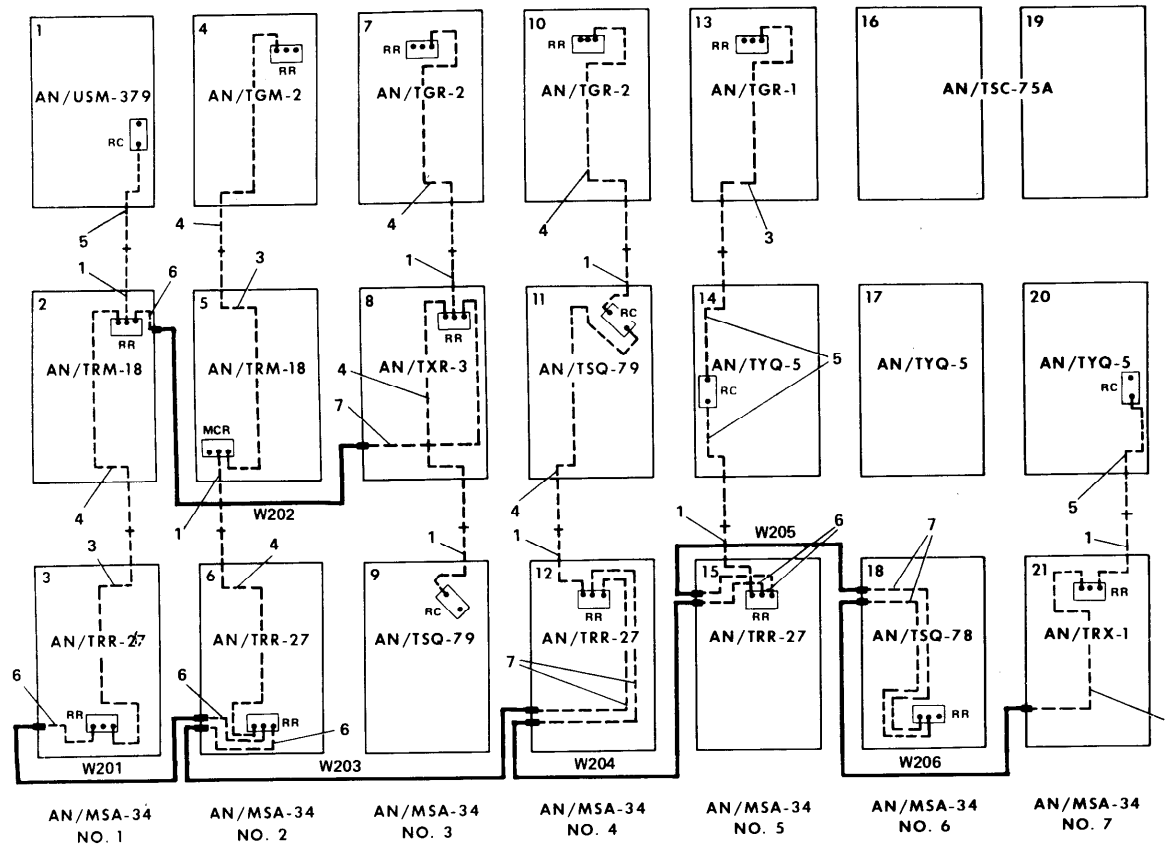

LEGEND:

- 1 THROUGH 21 - INDICATE THE 21 S-389/MSA-34 ELECTRICAL EQUIPMENT SHELTERS
- MCR - MASTER CLOCK: RACK
- RR - REMOTE DISPLAY: RACK
- RC - REMOTE DISPLAY: CEILING
- EXTERNAL CABLES TO BE INSTALLED AT SITE
- - - INTERNAL CABLES ALREADY INSTALLED

INTERCONNECTION CABLES

| ITEM | IDENT NO. | QUANTITY | LENGTH | DESCRIPTION |
|------|-----------|----------|--------|---------------|
| 1 | W211 | 8 | 6'0" | 0283-4-4831-1 |
| 3 | W213 | 3 | 32'0" | 0283-4-4831-3 |
| 4 | W214 | 7 | 32'0" | 0283-4-4831-4 |
| 5 | W215 | 4 | 16'0" | 0283-4-4831-5 |
| 6 | W216 | 6 | 6'0" | 0283-4-4831-6 |
| 7 | W217 | 6 | 6'0" | 0283-4-4831-7 |
| | W201 | 1 | 25'0" | 0283-4-3830-1 |
| | W202 | 1 | 25'0" | 0283-4-3830-2 |
| | W203 | 1 | 25'0" | 0283-4-3830-3 |
| | W204 | 1 | 25'0" | 0283-4-3830-4 |
| | W205 | 1 | 25'0" | 0283-4-3830-5 |
| | W206 | 1 | 25'0" | 0283-4-3830-6 |

Figure 1-6. Digital Clock Subsystem

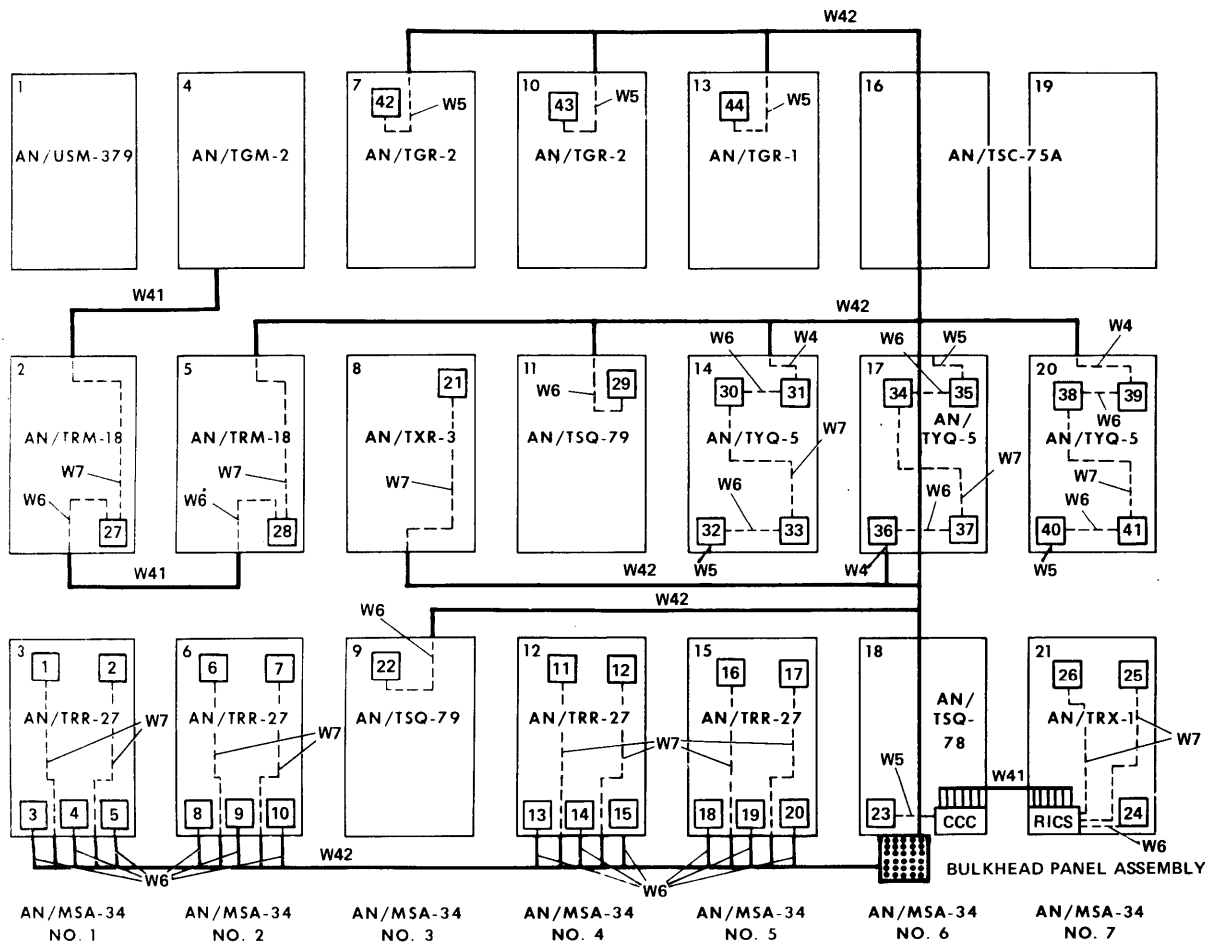

LEGEND:

- 1 THROUGH 21 - INDICATE THE 21 S-389/MSA-34 ELECTRICAL EQUIPMENT SHELTERS
- CCC - CONSOLE COMMUNICATION CONTROL AND SWITCHBOARD
- RICS - RADIO INTERCEPT CONTROL SWITCHBOARD
- 1 THROUGH 21 - PANEL MONITOR SB-2600/G
- 22 THROUGH 44 - TELEPHONE SET TA-676(1)/G
- EXTERNAL CABLES TO BE INSTALLED AT SITE
- - - INTERNAL CABLES ALREADY INSTALLED

INTERCONNECTION CABLES

| IDENT NO. | QUANTITY | LENGTH | DESCRIPTION |
|-----------|----------|--------|---------------|
| W41 | 8 | 12'0" | 0283-4-3860-1 |
| W42 | 30 | 75'0" | 0283-4-3860-2 |
| W4 | 3 | 4'0" | 0283-4-4011-4 |
| W5 | 16 | 6'0" | 0283-4-4011-5 |
| W6 | 14 | 12'0" | 0283-4-4011-6 |
| W7 | 15 | 32'0" | 0283-4-4011-7 |

Figure 1-7. Intercommunication Subsystem

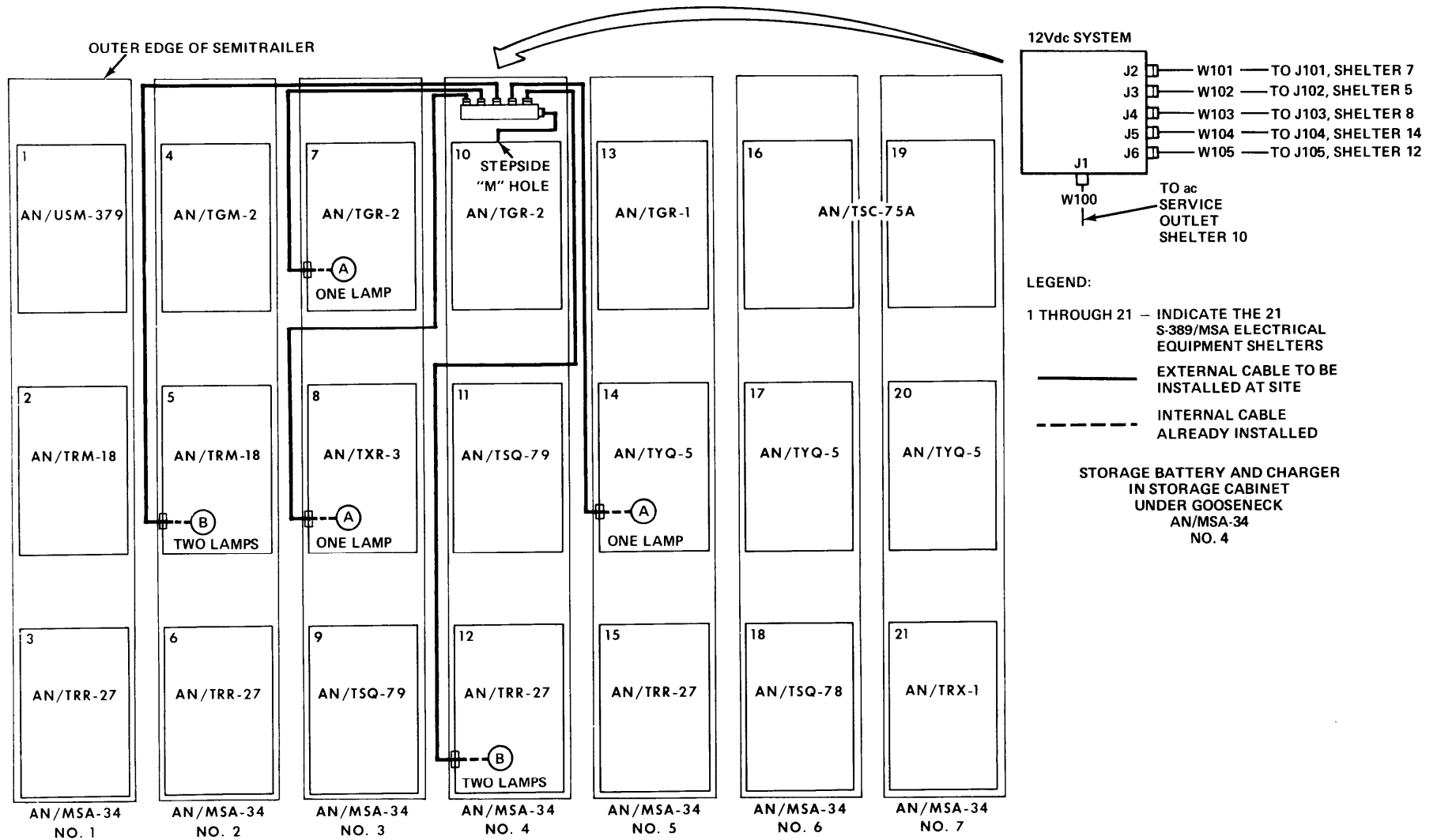

Figure 1-8. Emergency Lighting Subsystem

CHAPTER 2

SERVICE UPON RECEIPT AND INSTALLATION

Section I. PREPARATION

2-1 GENERAL. The OUTS is designed for a specific layout of components; all interconnectors are designed for a specific location.

2-2 SITE SELECTION. In selecting a location for setting up the OUTS, the following precautions should be observed:

a. The location must be large enough for maneuvering the equipment into position and must provide access for servicing the installation.

b. The site area should be substantially flat for at least 150 yards in all directions from the center of the site, with no more than a gentle slope for several times that distance.

c. The site area should be as firm as possible for an area approximately 60 by 65 feet where the OUTS will be installed.

d. The site should be the highest level available in the general vicinity, but mountainous or hilly country should be avoided when possible.

e. The site should have natural drainage. Swampy or spongy ground sites surrounded by close, high ground must be avoided.

f. Dry stream beds should be avoided since they are subject to flash flooding in the event of sudden storms.

2-3 SITE PREPARATION. Prepare the site as follows:

a. Clear the site so that operators can use the equipment with maximum efficiency. Maximum slope angle can be 1 degree (approximately 1/4-inch drop per foot) without dunnage. Greater slope requires 4-inch dunnage for each 1-degree increase in slope angle.

b. Ensure that the area has good drainage by filling depressions and constructing gentle slopes and ditches to provide for controlled runoff.

Section II. SERVICE UPON RECEIPT OF EQUIPMENT

2-4 UNPACKING. Each of the seven AN/MSA-34 units is shipped completely assembled and ready for use. Unpacking is limited to removing the waterproof, self-adhesive type tape around shelter openings and removing components used for installation from their tiedown positions on the trailer.

2-5 CHECKING UNPACKED EQUIPMENT.

a. Inspect the equipment for any damage incurred during shipment. If the equipment has been damaged, report the damage on DD Form 6 in accordance with paragraph 1-2.

b. To determine if the shipment is complete, check the equipment against the component listing in the operator's manual and the packing slip. Report all discrepancies in accordance with paragraph 1-2. The equipment should be placed in service, even though a minor assembly or part, that does not affect proper functioning, is missing.

c. Check for modification of equipment. Equipment which has been modified will have the Modification Work Order (MWO) number on the front panel near the nomenclature plate.

d. Ensure that all currently applicable MWO'S have been applied. Current MWO'S applicable to the equipment are listed in USASA PAM 310-6 or DA PAM 310-7.

Section III. INSTALLATION

2-6 GENERAL. These instructions cover the on-site installation of a seven-AN/MSA-34 unit complex as shown in figure 2-1. The positioning of the seven AN/MSA-34 units should start by positioning the AN/MSA-34 No. 7 semitrailer on the highest part of the 60 by 65-foot site, so that each of the other semitrailers can be leveled up to No. 7. After No. 7 semitrailer is in position, No. 6 and the other five semitrailers in turn should be placed side by side. Alignment should be within the following allowable limits:

NOTE

All dimensions refer to distances between outside faces of the first and third shelters on any two semitrailers.

- (1) Side-to-side distance: 20 inches to 24 inches.
- (2) End-to-end distance: In line to ± 2 inches.
- (3) Up and down distance: Level to ± 2 inches.

CAUTION

Designate only one person to give directions to the tractor driver. Be sure all unauthorized personnel are clear of the area before positioning trailers.

2-7 TOOLS REQUIRED FOR INSTALLATION. No special tools are required for installation. A set of common wrenches, provided for installation setup, are stored in the cabinet under the gooseneck section of the semitrailer.

2-8 AN/MSA-34 INSTALLATION. Each AN/MSA-34 should be positioned, leveled, and grounded as follows:

a. *Positioning.* Position an AN/MSA-34 as follows:

- (1) Place the semitrailer in the desired position and apply the semitrailer brakes by operating the air-brake controller in the truck-tractor cab.
- (2) Set the semitrailer parking brakes by use of the hand lever on the rear wheels.
- (3) Remove flotation pads from their transit storage position and slide on to the semitrailer landing-gear feet.
- (4) Remove the two crank handles from the semitrailer storage cabinet and install on the landing-gear crankshafts.

CAUTION

If landing-gear pads settle deeply into the earth, retract landing gear and provide increased bearing area by placing timber or planks under landing-gear pads, and then repeat the step.

(5) Turn the two landing-gear cranks simultaneously to lower the landing-gear pads until the pads bear firmly on the earth to support the front of the semitrailer.

(6) Close the cutoff cocks on the tractor air-brake hoses.

(7) Disconnect both airbrake hoses from the semitrailer by raising and rotating each hose coupling until it is free. Disconnecting the airbrake hoses automatically sets the semitrailer brakes.

(8) Place dummy couplers on semitrailer couplings and couple the tractor airbrake hoses together to exclude dirt from the brake systems.

(9) Disconnect the tractor dc power cable from the semitrailer connector and see that the hinged cover on the semitrailer receptacle closes.

CAUTION

Be sure to move the truck tractor slowly to minimize the impact of the transfer of trailer weight to the landing gear and flotation pads.

(10) Move the coupler-release lever on the tractor fifth wheel to the unlocked position, and drive the truck tractor forward slowly. Allow the fifth wheel to clear the kingpin on the semitrailer.

b. *Leveling.* Level the AN/MSA-34 as follows:

- (1) Unbolt the four leveling jacks on the semitrailer from the retainer clips. Pull jacks out, swing them down, push them back into the frame, and store the fasteners on the retainer clips.
- (2) Remove jack braces from storage and install them on the bottom of the jack tubes and the semitrailer frame cross-members. Tighten all bolts.
- (3) Place flotation pads on all jack swivel feet.
- (4) Insert the two crank handles on the two rear-most jacks and turn the cranks simultaneously until all rear wheels clear the ground.

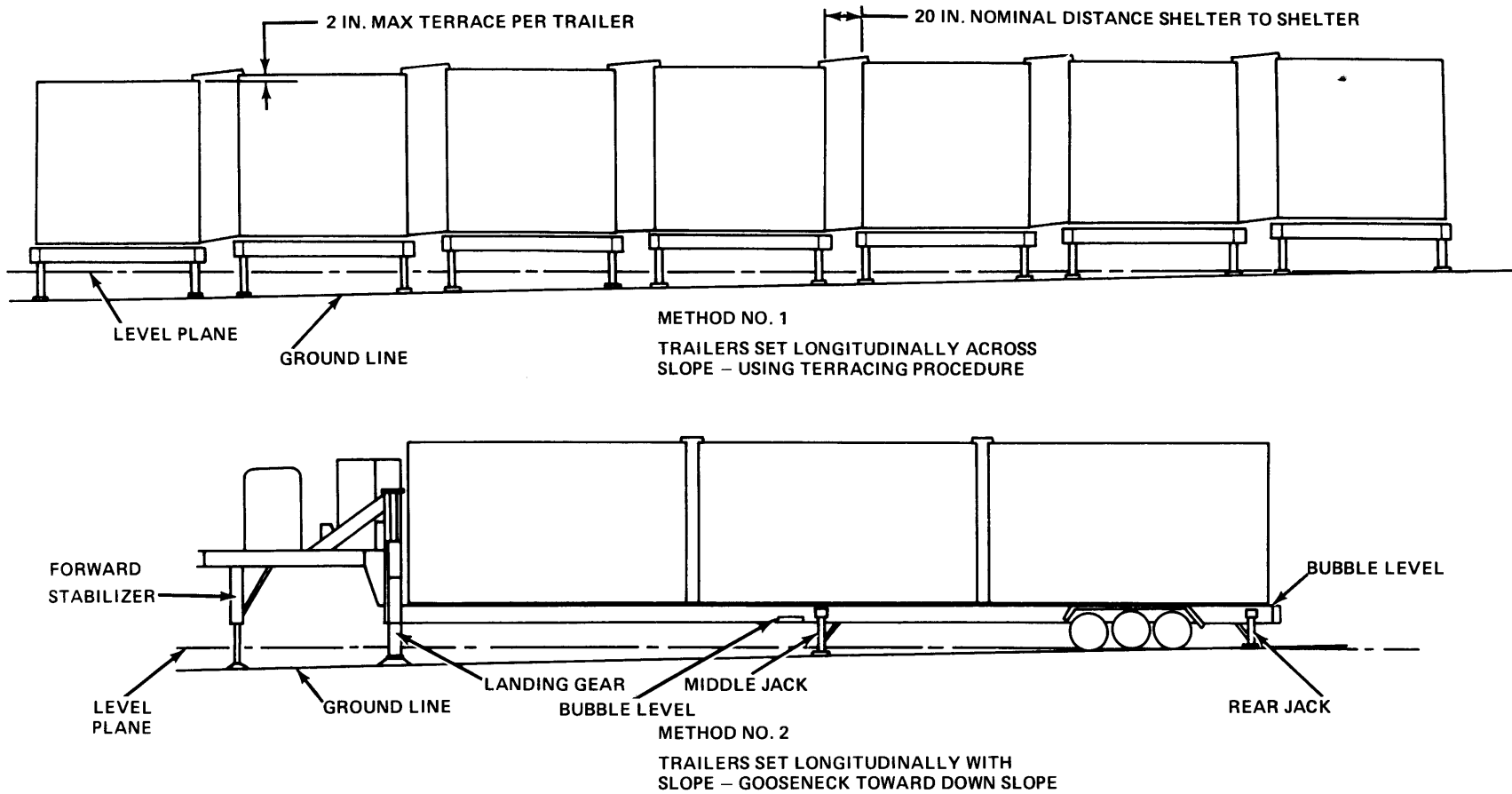

MAXIMUM SLOPE ANGLE 1° (1/4 IN. PER 1 FT APPROXIMATELY) WITHOUT USE OF DUNNAGE, METHOD 1 OR 2. SLOPE ANGLE MAY BE INCREASED BY USE OF DUNNAGE UNDER THE DOWNSLOPE PADS OF TRAILER STABILIZERS OR JACKS. EACH 4 IN. OF DUNNAGE INCREASES SLOPE ANGLE APPROXIMATELY 1° .

Figure 2-1. Installation of a Seven-AN/MSA-34 Unit Complex

(5) Adjust the jacks so that the rear of the semi-trailer is level as shown by the bubble level on the semitrailer bumper.

NOTE

If the trailer is sitting on a noticeable slope, it may be necessary for the wheels on the high side to contact the ground when the semitrailer is level. Wheels must be raised enough to relieve the spring compression in the running gear.

(6) Remove the two crank handles from the rear jacks, insert them in the landing crank shafts and adjust the jacks so that the semitrailer is level from front to back, as shown by the bubble level on the road-side frame of the semitrailer. Adjust the landing gear to level the front of the trailer.

(7) Remove the two crank handles from the landing-gear jacks, insert them in the middle jacks, and adjust the jacks to stabilize the center of the semitrailer. Return the crank handles to storage.

c. Stabilizing. Stabilize the AN/MSA-34 only when the 30-kW generator is mounted on the trailer goose-neck. Stabilize as follows:

(1) Remove the two forward stabilizers from storage on the diagonal support struts on the gooseneck by removing the bolts on the swivel pads and sliding the stabilizers up out of the storage pocket. Store the fasteners on the support struts.

(2) Place the forward stabilizers in the sockets in the gooseneck and secure with the captive hardware. Bolt the braces on the stabilizers to the brackets on the gooseneck.

(3) Remove the release pin on each stabilizer tube and allow the inner tube of the stabilizer to drop the swivel feet to the ground.

(4) Raise the inner tube until the first hole position lines up and insert the release pin in the hole.

CAUTION

If any jack or stabilizer swivel foot or flotation pad tends to sink into the earth during leveling operations, retract and provide increased bearing area by placing timber or planks under flotation pads, and then repeat the step.

(5) Use the open-end wrench supplied with the semitrailer and turn the adjusting screw on the lower end of the inner tube until the jack swivel foot is firm on the earth; continue for two additional full turns.

d. Grounding. The AN/MSA-34 is shipped with ground connections in place, except for trailer-to-earth, which must be made as follows:

(1) Select a grounding site approximately 12 feet from the ground lug on each end of the semitrailer frame, and scoop out a hole about 6-inches deep at both locations.

(2) Remove the two ground rods from their storage position on the roadside trailer frame.

(3) Drive a ground rod in each hole until the top of the rod is approximately 12 inches above the bottom of the hole.

(4) Saturate the ground around the rod with water.

(5) Remove the ground cables from the semitrailer storage cabinet and connect the ground rods to the ground lugs on the semitrailer.

2-9 WALKWAY INSTALLATION.

a. General. The shelters must be interconnected end-to-end and side-to-side by walkways as shown in figure 2-2. Each interconnect procedure consists of removing panels, storing panels, and installing walkway kits which consist of walkway covers and walkway treads. Refer to TM 32-5410-217-14&P for additional information.

b. Panel Removal. Remove the panels at two abutting openings as follows:

(1) Station two persons in the shelter and two on the roof over the panel to be removed.

(2) Loosen but do not remove shelter tiedown slings.

(3) Inside the shelter, loosen clamps around the periphery of the panel by loosening the screws.

(4) Rotate all panel clamps 90° to release panel from shelter and tighten the clamps in the release position while the panel is held in position by the persons on the roof.

(5) Push panel outward and lift up, using stand-offs as handles. Persons on roof will lift panel to roof.

(6) Repeat steps (1) through (5) to remove abutting panel.

Figure 2-2. Shelter Walkway Interconnections

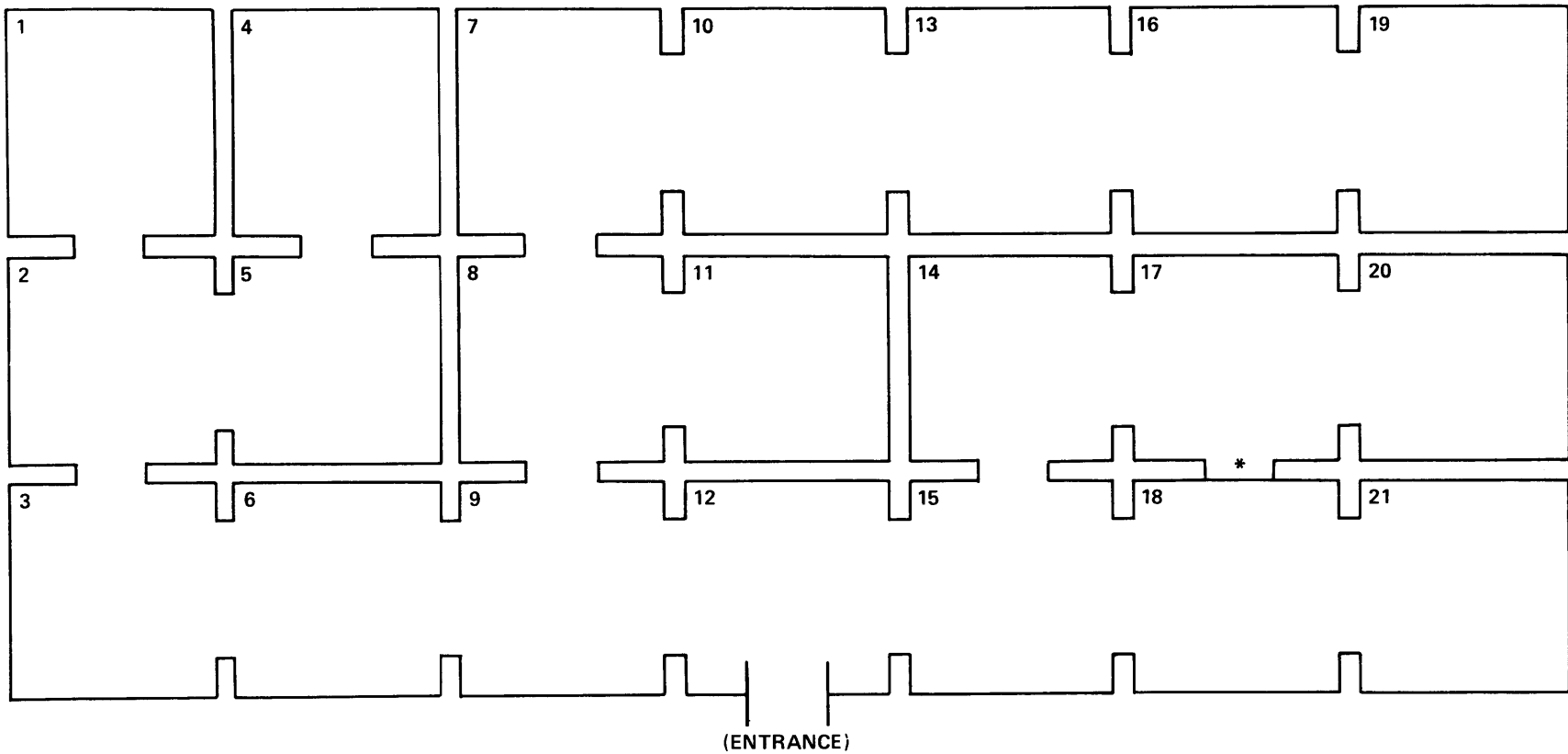

LEGEND:

**1 THROUGH 21 – INDICATE THE 21
S-389/MSA-34 ELECTRICAL
EQUIPMENT SHELTERS**

***THIS IS NOT A PASSAGEWAY FOR PERSONNEL.**

Figure 2-2. Shelter Walkway Interconnections

c. Panel Storage. Store panels on roof as follows:

(1) Unlatch tensioner device on all straps on the inside panel face and unhook straps from storage position.

(2) Release the panel standoff under the straps from its storage position. To release, reach through opening in the standoff, pull the spring pin out, and rotate the standoff from the flush position. The spring pin will relock when the standoff is fully out.

(3) Position the panel on the roof, standoff side down, and place standoffs in pockets in the roof.

(4) Hook loose tiedown strap ends to loops on the roof and relatch strap-tensioner devices to fasten panel to the roof.

d. End-Walkway Cover Installation. Install end-walkway covers as follows:

(1) Remove walkway cover from storage in shelter and lift on to roof at position to be connected.

(2) Rotate cover screw jacks to pull cover to minimum thickness.

(3) Place cover into position between shelters and allow top of cover to hold it in position.

(4) Install two cover top clamps, a right and a left on each shelter. To install clamp, position over shouldered pins in the shelter roof and push clamps to engage pins in key slot.

(5) From inside the shelter, rotate the cover screw jacks to expand the cover to fill the space between the shelters.

(6) On roof, rotate top clamps down to compress top of cover to shelters.

(7) Ensure that gasketing on cover contacts shelter and that lip pieces at bottom of cover are in contact with shelter panel opening extrusion. Adjust screw jacks and clamps, as required, for weatherproof seal.

e. Side-Walkway Cover Installation. Install side-walkway (wide) covers as follows:

(1) Remove walkway cover package from storage in shelter and separate into a top, a bottom, two side sections, and a bow assembly.

(2) Rotate screw jacks on all parts to reduce width so that gap is cleared between shelters.

(3) Position bottom part in place with the lip pieces along bottom nesting around the edge of shelter panel opening extrusion. Rotate screw jacks to spread bottom part between shelters.

(4) Lift top section to roof at position to be connected.

(5) Install three center-type top clamps, one right-end top clamp, and one left-end top clamp on each shelter. To install clamps, position over shouldered pins in the shelter roof and push clamps to engage pins in the key slots. The end top clamps will straddle the castings in the shelter roof.

(6) Position top section in place and rotate screw jacks to spread short legs against shelter. Rotate top clamps down to compress top section to shelter.

(7) Install side sections from inside shelter, inserting pins on the sections into holes in the side of the shelters. The side sections are installed inside the side flaps of the top section and outside the upright legs on the bottom section. Rotate screw jacks to spread side sections between shelters.

(8) From outside of cover assembly, snap the “lift the dot” type fasteners, top and bottom, to completely close the assembly.

(9) Check to see that gasketing on the cover contacts the shelter, and that the lip pieces at bottom of cover are in contact with the shelter-panel opening extrusion. Adjust screw jacks and clamps, as required, for weatherproof seal.

f. Walkway Tread Installation. Install walkway treads as follows:

NOTE

Walkway treads are supplied with two interchangeable bolt-on angles. The long-leg angle is used if both panels are removed; the short-leg angle is used if a door type panel is left in position. Select and bolt on the desired angle prior to proceeding with installation.

(1) Remove the walkway tread from its storage position on the carrier/stabilizer above the air conditioners.

(2) Lay the walkway tread in place across the bottom of the cover and adjust the width to suit the span between cover framing.

(3) Fasten the tread to cover framing with the 12 quarter-turn screw devices provided.

2-10 AIR CONDITIONING DUCT-CONNECT INSTALLATION.

a. General. The OUTS is normally transported with the air-conditioning ducts of the shelters and plenum on the semitrailer interconnected by return and supply connect-ducts. Ensure that connect-ducts are installed.

b. Installation. If cover plates are on the duct openings, install the connect-ducts as follows:

(1) Remove the watertight covers from the duct openings and store the covers on the brackets near the duct openings.

(2) Remove the connect-ducts from storage in the shelters and install connect-ducts between abutting duct openings, using the same screws that held the covers over the openings.

2-11 INTERNAL POWER-SOURCE CONNECTIONS.

Each of the seven AN/MSA-34 units is shipped completely connected for operation on ac power supplied by its own 30-kW generator set, located on the semitrailer gooseneck, as shown in figure 1-4. There are no ac power connections from one AN/MSA-34 to any other AN/MSA-34.

2-12 GENERATOR EXHAUST STACK EXTENSION.

a. To prepare the 30-kW generator set for operation, the exhaust stack must be extended to prevent exhaust gases from being drawn into the air conditioners.

b. The exhaust-stack extension must be installed as follows:

(1) Remove exhaust-stack extension from storage position on the semitrailer gooseneck in front of the generator set by loosening the screw on the roadside bracket and sliding the exhaust stack extension out.

(2) Remove weather-flap shield from stub end of exhaust elbow on the generator set. Install the weather-flap shield on the upper end of the exhaust-stack extension.

(3) Slide the lower end of the exhaust-stack extension on the stub end of the exhaust elbow on the generator set.

(4) Unfold exhaust-stack extension brace to open position and lock by sliding collar over fold joint.

(5) Install end of brace in hole on semitrailer frame. The extension may be rotated on the exhaust elbow, as required, during installation.

2-13 EXTERNAL POWER SOURCE CONNECTIONS.

WARNING

Be sure to ground each AN/MSA-34 and set all switches to the OFF position prior to connection of external power source. Failure to do so may result in severe electrical shock and/or damage to equipment.

a. General. When the ac power is to be supplied by a separate 200-kW generator set or by a locally available commercial source, the 30-kW generator set must be disconnected and the external power connection made to each AN/MSA-34.

b. Disconnection of 30-kW Generator Set. Disconnect the 30-kW generator set power cable as follows:

(1) Remove outer weather cover on power distribution box, located on roadside of semitrailer gooseneck. (See figure 1-4.)

(2) Place circuit breaker to OFF position.

(3) Remove four screws inside power distribution box and remove inside protective cover.

(4) Remove generator power-cable connections from three places on the circuit breaker and from one place on the terminal board. Tag each wire for identification during replacement.

(5) Loosen cable clamp on bottom of power distribution box and pull the generator power cable from the box.

(6) Wrap each connection on the power cable individually with electrical insulation tape and tape over the entire end.

(7) Coil the generator power cable, tape or tie the coil, and store at the 30-kW generator set.

c. External Power Connections. External power, when available, is connected to an OUTS power distribution box, and from the OUTS power distribution box to the seven AN/MSA-34 power distribution boxes as shown in figure 1-4. Connect the external power to the seven AN/MSA-34 units as follows:

(1) Remove the OUTS power distribution box and the external power cables from the transport position on the truck.

(2) Set up the OUTS power distribution box a short distance in front of AN/MSA-34, No. 4.

(3) Prepare leads of weatherproof, heavy-duty, 208-V, 100-A, 4-wire power cables for connections to the AN/MSA-34 power distribution boxes, the OUTS power distribution box, and the external power source.

(4) Install a heavy-duty power cable on each AN/MSA-34 power distribution box through the cable clamp, and connect the leads as follows: phase 1 to A, phase 2 to B, and phase 3 to C on the circuit breaker, and neutral lead to LO on the terminal board. Tighten cable clamp on bottom of power distribution box, and install the protective cover removed in subparagraph b(3) above. Connect other end of each cable to the connector in the OUTS power distribution box marked for the respective AN/MSA-34 number.

(5) Install the heavy-duty power-cable INPUT by connecting one end of the leads to the OUTS power distribution INPUT, and the other end of the leads to the external power-source outlet.

2-14 ANTENNA DISTRIBUTION SUBSYSTEM CONNECTIONS. The OUTS is normally transported with all Antenna Distribution Subsystem components installed and interconnected, except for RF cables W1 through W59 which interconnect the seven AN/MSA-34 units as shown in figure 1-5. These cables are rolled up and stowed in shelter 18 for transport. After the seven AN/MSA-34 units are positioned and interconnected by walkways, the external RF cables used in the Antenna Distribution Subsystem will be installed as follows:

CAUTION

The ac power to the AN/GRQ-23, RF Switching Set, must be OFF when RF cables are connected or disconnected, because all RF cables carry dc control voltage, and shorting or grounding will damage equipment.

- a. Remove cables W1 through W59 from their stowed position.
- b. Place the ON-OFF switch on the AN-GRQ-23 in the OFF position.
- c. Interconnect the shelters on the seven AN/MSA-34 units by installing cables W1 through W59 as shown in figure 1-5, making the connections listed in table 2-1.

Table 2-1. ANTENNA DISTRIBUTION INTERCONNECTIONS

| CABLES | FROM SHELTER | TO SHELTER |
|-----------------|---------------|------------|
| W1 through W10 | 18 | 15 |
| W11 through W20 | 18 | 12 |
| W21 through W30 | 18 | 6 |
| W31 through W40 | 18 | 3 |
| W41 through W45 | 18 | 21 |
| W46 through W47 | 18 | 8 |
| W48 through W51 | 18 | 7 |
| W52 through W55 | 18 | 10 |
| W56 through W57 | 18 | 13 |
| W58 | 18 | 5 |
| W59 | 18 | 2 |
| W60 | 18 (Internal) | 18 |

Connector numbers correspond to cable numbers.

- d. Connect the antennas to the OUTS by installing cables W61 through W70 to make the following connections at shelter 18 as listed in table 2-2.

Table 2-2. ANTENNA INPUT CONNECTIONS

| CABLE | FROM SHELTER/ CONNECTOR | TO ANTENNA |
|-------|----------------------------|----------------------------|
| W61 | 18/J61 | No. 1 AN/MRA-17 vertical |
| W62 | 18/J62 | No. 1 AN/MRA-17 horizontal |
| W63 | 8/J63 | No. 2 AN/MRA-17 vertical |
| W64 | 8/J64 | No. 2 AN/MRA-17 horizontal |
| W65 | 18/J65 | No. 3 AN/MRA-17 vertical |
| W66 | 18/J66 | No. 3 AN/MRA-17 horizontal |
| W67 | 18/J67 | No. 4 AN/MRA-17 vertical |
| W68 | 18/J68 | No. 4 AN/MRA-17 horizontal |
| W69 | 18/J69 | No. 5 AN/MRA-17 vertical |
| W70 | 18/J70 | No. 5 AN/MRA-17 horizontal |
| | J71 | |
| | SPARES J72 | |
| | J73 | |

2-15 DIGITAL CLOCK SUBSYSTEM CONNECTIONS. The OUTS is normally transported with all Digital Clock Subsystem components installed and interconnected, except for the external signal cables W201 through W206, which interconnect the seven AN/MSA-34 units, as shown in figure 1-6. These external cables are rolled up and stowed in the storage cabinet in the AN/TSQ-78, shelter 18. After the seven AN/MSA-34 units are positioned and interconnected by walkways, make the interconnections listed in table 2-3, as follows:

- a. Remove cables W201 through W206 from their stowed position.
- b. Interconnect the seven AN/MSA-34 units by installing cables as listed in table 2-3 and as shown in figure 1-6.

Table 2-3. DIGITAL CLOCK INTERCONNECTIONS

| CABLE | FROM SHELTER | TO SHELTER |
|---------|--------------|------------|
| W 2 0 1 | 3 | 6 |
| W 2 0 2 | 2 | 8 |
| W 2 0 3 | 6 | 1 2 |
| W 2 0 4 | 12 | 1 5 |
| W 2 0 5 | 15 | 1 8 |
| W 2 0 6 | 18 | 2 1 |

2-16 INTERCOMMUNICATION SUBSYSTEM CONNECTIONS.

a. The OUTS is normally transported with all intercommunication components installed and interconnected, except for the cabling necessary to interconnect the seven AN/MSA-34 units. For transport, the external cables are disconnected, rolled up, and stored in the storage cabinet located in the AN/TSQ-78, shelter 18. The six internal cables, used to interconnect the Communications Control Console (CCC), in the AN/TSQ-78, shelter 18, and the Radio Intercept Control Switchboard (RICS), in the AN/TRX-1, shelter 21, are disconnected from the RICS end and are rolled up under the CCC, still connected at the CCC end.

b. After the seven AN/MSA-34 units are positioned and their interconnecting walkways installed, remove the 38 intercommunication connecting cables from their stowed positions and install them as shown in figure 1-7 and as listed in table 2-4, with the following notations:

Table 2-4. INTERCOMMUNICATION SUBSYSTEM INTERCONNECTIONS

| FROM SHELTER NO. | TO SHELTER NO. | CABLES |
|------------------|----------------|------------|
| 1 8 | 21 | W41 (6 ea) |
| 5 | 2 | W41 (1 ea) |
| 2 | 4 | W41 (1 ea) |
| 1 8 | 15 | W42 (5 ea) |
| 1 8 | 12 | W42 (5 ea) |
| 1 8 | 9 | W42 (1 ea) |
| 1 8 | 6 | W42 (5 ea) |
| 1 8 | 3 | W42 (5 ea) |
| 1 8 | 20 | W42 (1 ea) |
| 1 8 | 17 | W42 (1 ea) |

Table 2-4. INTERCOMMUNICATION SUBSYSTEM INTERCONNECTIONS (Continued)

| FROM SHELTER NO. | TO SHELTER NO. | CABLES |
|------------------|----------------|------------|
| 1 8 | 1 4 | W42 (1 ea) |
| 1 8 | 1 3 | W42 (1 ea) |
| 1 8 | 1 1 | W42 (1 ea) |
| 1 8 | 1 0 | W42 (1 ea) |
| 1 8 | 8 | W42 (1 ea) |
| 1 8 | 7 | W42 (1 ea) |
| 1 8 | 5 | W42 (1 ea) |

(1) Unroll the six 12-foot (W41) cables stowed under the CCC in shelter 18 and connect them to the RICS in shelter 21, passing the cables through the open passageway connecting the two shelters.

(2) Interconnect shelters 5 and 2 and shelters 2 and 4, using two 12-foot (W41) cables, passing the cables through the cable feed-throughs (M-holes) in each of these shelters.

(3) Connect the 30, 75-foot (W42) cables to the 30-line pass-through panel, located on the rear door of shelter 18.

(4) Connect five each of the W42 cables to each of the 5-line pass-through panels on shelters 3, 6, 12, and 15.

(5) Connect one each of the remaining W42 cables to shelters 5, 7, 8, 9, 10, 11, 13, 14, 17, and 21, using the 1-line pass-through connector at each shelter.

c. Table 2-5 lists the Intercommunication Subsystem facilities in each of the shelters.

Table 2-5. INTERCOMMUNICATION FACILITIES IN SHELTERS

| SHELTER NO. | NUMBER OF UNITS | TYPE OF UNITS |
|-------------|-----------------|---------------|
| 1 | None | None |
| 2 | 1 | TA-676/G |
| 3 | 5 | SB-2600/G |
| 4 | None | None |
| 5 | 1 | TA-676/G |
| 6 | 5 | SB-2600/G |
| 7 | 1 | TA-676/G |

Table 2-5. INTERCOMMUNICATION FACILITIES IN SHELTERS (Continued)

| SHELTER NO. | NUMBER OF UNITS | TYPE OF UNITS |
|-------------|-----------------|---------------|
| 8 | 1 | SB-2600/G |
| 9 | 1 | TA-676/G |
| 10 | 1 | TA-676/G |
| 11 | 1 | TA-676/G |
| 12 | 5 | SB-2600/G |
| 13 | 1 | TA-676/G |
| 14 | 4 | TA-676/G |
| 15 | 5 | SB-2600/G |
| 16 | None | None |
| 17 | 4 | TA-676/G |
| 18 | 2 | OA-7735 |
| 18 | 1 | TA-676/G |
| 18 | 1 | SB-2601/G |
| 19 | None | None |
| 20 | 4 | TA-676/G |
| 21 | 1 | SB-2602/G |
| 21 | 3 | TA-676/G |

2-17 EMERGENCY LIGHTING SUBSYSTEM CONNECTIONS. The OUTS is normally transported with all emergency lighting components installed and interconnected, except for cables W100 through W105, which are rolled up and stowed near the emergency power-source assembly in the storage cabinet of AN/MSA-34 No. 4. These cables will be installed as shown in figure 1-8 and listed in table 2-6 as follows:

Table 2-6. EMERGENCY LIGHTING SYSTEM INTERCONNECTIONS

| CABLE | FROM | TO |
|-------|-----------------------|---------|
| W100 | AC outlet, shelter 10 | ELS, J1 |
| W101 | J101, shelter 7 | ELS, J2 |
| W102 | J102, shelter 5 | ELS, J3 |
| W103 | J103, shelter 8 | ELS, J4 |
| W104 | J104, shelter 14 | ELS, J5 |
| W105 | J105, shelter 12 | ELS, J6 |

- a. Remove cables W100 through W105 from their stowed location.
- b. Place override toggle switch on the emergency power source assembly in OFF position.
- c. Connect cable W101 from J101 on shelter 7 to J2 on the emergency power source.
- d. Connect cable W102 from J102 on shelter 5 to J3 on the emergency power source.
- e. Connect cable W103 from J103 on shelter 8 to J4 on the emergency power source.
- f. Connect cable W104 from J104 on shelter 14 to J5 on the emergency power source.
- g. Connect cable W105 from J105 on shelter 12 to J6 on the emergency power source.
- h. Connect cable W100 from the ac outlet receptacle in shelter 10 to J1 on the bottom of the emergency power source.
- i. Place override toggle switch on the emergency power source assembly in ON position, only when emergency lighting in the shelters may be needed.

NOTE

A fully charged battery will only provide shelter illumination for 2-1/2 hours.

CHAPTER 3

OPERATING INSTRUCTIONS

3-1 GENERAL. The operating instructions for the OUTS subsystems, except for the Emergency Lighting Subsystem, are contained in subsystems' technical manuals.

3-2 POWER DISTRIBUTION SUBSYSTEM. For Power Distribution Subsystem operating instructions, refer to TM 32-9999-200-15-1.

3-3 ANTENNA DISTRIBUTION SUBSYSTEM. For Antenna Distribution Subsystem operating instructions, refer to TM 32-5895-753-14.

3-4 DIGITAL CLOCK SUBSYSTEM. For Digital Clock Subsystem operating instructions, refer to TM 32-4940-200-14.

3-5 INTERCOMMUNICATION SUBSYSTEM. For Intercommunication Subsystem operating instructions, refer to TM 32-5895-227-14, the instruction manual for the Communications Central, AN/MSQ-71.

3-6 EMERGENCY LIGHTING SUBSYSTEM. The operating instructions for the Emergency Lighting Subsystem are as follows:

a. The Emergency Lighting Subsystem will operate automatically when the interconnecting cables are installed in accordance with paragraph 2-17, and the override toggle switch is in the ON position. When ac power is available, the relay-controlled switch disconnects the storage battery from the emergency lights and connects the storage battery to the battery charger, which adjusts its rate of charge from approximately one ampere to 10 amperes, depending on the condition of the battery. In absence of ac power, the relay-controlled switch disconnects the battery charger from the battery, and connects the battery to the lights. The fully charged battery will furnish power for operation of the lights for more than 2 hours. The override toggle switch, in the OFF position, disconnects the storage battery from the lights. This disconnection of the battery is desirable when the OUTS complex is shut down, unoccupied, or otherwise not in need of interior illumination. When ac power is restored, the battery will be charged as necessary to achieve and maintain its rated capacity.

b. The emergency lighting controls and indicators are described in table 3-1 and shown in figure 3-1.

Table 3-1. EMERGENCY LIGHTING CONTROLS AND INDICATORS

| CONTROL OR INDICATOR | FUNCTION |
|--|--|
| Override toggle switch (in emergency power supply) | OFF position disconnects emergency power source from cables to lamps. ON position connects emergency power source to cables to lamps. |
| DC ammeter (on battery charger) | Indicates battery charging rate (10-A maximum, 1-A minimum). |
| Emergency lamp | Illuminates when ac power is not present and override toggle switch is in ON position. |

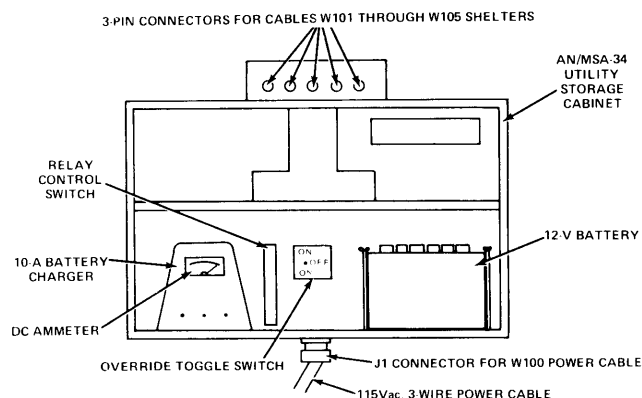

Figure 3-1. Emergency Lighting Power Source Assembly

CHAPTER 4

OPERATOR/CREW MAINTENANCE INSTRUCTIONS

Section I. TOOLS AND EQUIPMENT

4-1 SPECIAL TOOLS, MATERIALS, AND EQUIPMENT REQUIRED. Tools, test equipment, and accessories issued with or authorized for use by the operator/crew for the OUTS are listed in the Maintenance Allocation Chart (MAC), Appendix B, of this manual. Use the MAC to determine maintenance task definitions and the assignment

of maintenance performance levels. Additional materials required for maintenance are:

- a. Cleaning Compound, Trichloroethane (NSN 7930-00-395-9542)
- b. Cloth, Textile, Cheesecloth (NSN 8305-00-267-3015)

Section II. LUBRICATION INSTRUCTIONS

4-2 LUBRICATION INSTRUCTIONS. The lubrication instructions for the equipment in OUTS are contained in

the applicable equipment manuals referenced in Appendix A.

Section III. PREVENTIVE MAINTENANCE CHECKS AND SERVICES

4-3 GENERAL. To ensure that the OUTS is always ready for operation, it must be inspected periodically and systematically so that defects may be discovered and corrected before they result in serious damage or failure. The necessary preventive maintenance checks and services to be performed are listed and described in table 4-1. In the sequence column, the numbers indicate the sequence of minimum inspection requirements. Defects discovered during operation of the item will be noted for future correction to be made as soon as operation has ceased. Stop operation immediately if a deficiency is noted during operation which would damage the equipment. Records and reports of all deficiencies together with the corrective action taken shall be made on the appropriate form(s) as directed by TM 38-750.

Table 4-1. OPERATOR/CREW DAILY PREVENTIVE MAINTENANCE

| Sequence | Item to be Inspected | Procedure | Reference |
|----------|----------------------|---|-----------|
| 1 | Connectors | Tighten all loose connections. | |
| 2 | Cables | Check that insulation is not cut, frayed, or broken. Remove all kinks and strain. | |
| 3 | Equipment | Use a clean cloth to remove dust, dirt, moisture, and grease from equipment exterior. If necessary, dampen cloth with cleaning compound, trichloroethane, then wipe parts with dry clean cloth. | |

WARNING

The fumes of cleaning compound, trichloroethane, are toxic. Provide adequate ventilation whenever it is used. **DO NOT USE NEAR OPEN FLAME.** Trichloroethane is not flammable, but exposure to open flame converts the fumes to a highly toxic and dangerous gas.

Table 4-1. OPERATOR/CREW DAILY PREVENTIVE MAINTENANCE (Continued)

| Sequence | Item to be Inspected | Procedure | Reference |
|----------|-----------------------|---|-----------|
| 3 | Equipment (Continued) | Check to ensure that all equipment performs satisfactorily. | |
| | | In case of operational failure of any equipment or circuit, refer to higher echelon of maintenance in accordance with Appendix B. | |
| 4 | Battery | Check electrolyte level. Add distilled water as necessary to maintain proper level. | |

4-4 SCOPE OF OPERATOR/CREW MAINTENANCE. The following duties normally are performed by the operator/crew:

- a. Preventive maintenance checks and services.
- b. Troubleshooting.
- c. Cleaning equipment surfaces.

4-5 PREVENTIVE MAINTENANCE CHECKS AND SERVICES. Preventive maintenance by the operator/crew consists of observation of the equipment during operation, and performance of the checks and services listed in table 4-1. These instructions apply to the Antenna Distribution Subsystem, the Digital Clock Subsystem, the Intercommunication Subsystem, the Emergency Lighting Subsystem, and the Power Distribution Subsystem.

Section IV. TROUBLESHOOTING

4-6 TROUBLESHOOTING. Troubleshooting by the operator/crew shall be limited to determining and locating a defective interconnection during preventive maintenance checks and services. Any trouble that is beyond the scope of operator/crew shall be referred to organizational maintenance.

4-7 CLEANING EQUIPMENT. The exterior surfaces of the equipment should be clean; that is, there should be no dust, dirt, grease, oil, or fungus on the surface.

- a. Remove dust and loose dirt with a clean cloth.

WARNING

The fumes of cleaning compound, trichloroethane, are toxic. Provide adequate ventilation whenever it is used. Do not use near an open flame. Trichloroethane is not flammable, but exposure to open flame converts the fumes to a highly toxic and dangerous gas.

- b. Remove grease, oil, fungus, and ground-in dirt from the equipment with a cloth dampened (not wet) with cleaning compound.

CAUTION

Use only clear water to clean plastic. Trichloroethane and other cleaning solvents attack plastic, causing it to become porous.

- c. If any equipment is washed using a waterhose, do not direct the water directly at the front panels and cable connectors. Wipe the equipment after using the waterhose.

NOTE

If equipment must be kept in continuous operation, check and service only those items that can be checked and serviced without disturbing operation; make complete checks and services when the equipment can be shut down.

CHAPTER 5

ORGANIZATIONAL MAINTENANCE INSTRUCTIONS

Section I. TOOLS AND EQUIPMENT

5-1 TOOLS AND TEST EQUIPMENT. The tools and test equipment for organizational maintenance are listed in the

Maintenance Allocation Chart (MAC), Appendix B.

Section II. REPAINTING AND REFINISHING INSTRUCTIONS

5-2 REPAINTING AND REFINISHING INSTRUCTIONS. The painting and refinishing instructions are

contained in the applicable equipment manuals listed in Appendix A.

Section III. LUBRICATION INSTRUCTIONS

5-3 LUBRICATION INSTRUCTIONS. The lubrication instructions for the equipments in OUTFITS are contained in

the applicable equipment manuals listed in Appendix A.

Section IV. PREVENTIVE MAINTENANCE CHECKS AND SERVICES

5-4 PREVENTIVE MAINTENANCE CHECKS AND SERVICES. Perform the periodic preventive maintenance checks and services listed in table 5-1. In the Sequence or Interval column, checks and services to be performed monthly are indicated by M and those to be performed quarterly are indicated by a Q. Defects that cannot be corrected must be reported to direct and general support maintenance.

Table 5-1. ORGANIZATIONAL PREVENTIVE MAINTENANCE CHECKS AND SERVICES

M – Monthly Q – Quarterly

| Sequence or Interval | Item to be Inspected | Procedure | Reference |
|----------------------|----------------------|--|-----------|
| M | Connectors | Examine all connectors. | |
| | | Bent pins should be straightened. | |
| | | Corroded contact surfaces should be cleaned to ensure good electrical contact. | |
| M | Cables | Examine all cables for sound condition. | |

NOTE

If the equipment must be kept in continuous operation, check and service only those items that can be checked and serviced without disturbing operation; make the complete checks and services when the equipment can be shut down.

NOTE

All checks are to be performed at initial installation and when the equipment is reinstalled after removal for any reason.

Table 5-1. ORGANIZATIONAL PREVENTIVE MAINTENANCE CHECKS AND SERVICES (Continued)

M – Monthly Q – Quarterly

| Sequence or Interval | Item to be Inspected | Procedure | Reference |
|----------------------|----------------------|--|-----------|
| M | Cables (Continued) | Cables with broken strands, cuts, or damage that might cause short circuits should be repaired with electrical tape or replaced. | |
| M | Battery | Check electrolyte level. Add distilled water as necessary to maintain proper level. | |
| | | Clean battery case of dust, dirt, grease, and moisture. | |
| | | Clean and tighten connections. | |
| M | Racks | Clean interior of racks with vacuum cleaner. | |
| M | Equipment Mountings | Tighten all loose bolts, nuts, screws, and clamps, and replace those that are missing. | |
| M | Equipment | Check out operation of all equipment. In case of failure of any equipment or circuit, refer to the applicable technical manual listed in Appendix A. | |
| Q | Completeness | Check all equipment for completeness. | |

Table 5-1. ORGANIZATIONAL PREVENTIVE MAINTENANCE CHECKS AND SERVICES (Continued)

M – Monthly Q – Quarterly

| Sequence or Interval | Item to be Inspected | Procedure | Reference |
|----------------------|--------------------------|--|---|
| Q | Completeness (Continued) | Requisition missing components or running spares. | |
| Q | Component Location | Check to see that all components are mounted or stowed in assigned places. | |
| Q | Publications | Check to see that all publications are complete, serviceable, and current. | |
| Q | Modifications | Determine if new, applicable MWO'S have been published. All urgent MWO's must be applied immediately; all normal MWO applications must be scheduled. | |
| Q | Preservation | Check all surfaces. | See TB-746-10 for cleaning and refinishing practices. |
| | | Remove fungus, rust, and corrosion, and paint bare surfaces. | |
| Q | Cables | Repair or replace defective cables, cords and wires. | |
| | | Dress all cabling, cords and wires, using cable clamps, electrical tape or lacing cord. | |
| Q | Lubrication | Lubricate components as required. | |

Section V. TROUBLESHOOTING

5-5 TROUBLESHOOTING. Troubleshooting by organizational personnel is limited to locating and correcting faults in the shelter-to-shelter interconnections and in the emergency lighting subsystem.

a. Troubleshooting the interconnections will include examination of connectors and cables, and substitution of a

known good component for one in question, when necessary to locate and correct a fault.

b. Troubleshooting the emergency lighting subsystem will include examination and correction of interconnecting cable and connector faults, in addition to performing the indicated checks and corrective measures listed in table 5-2. If the indicated corrective measures do not correct the trouble, a higher category of maintenance is required.

Table 5-2. EMERGENCY LIGHTING TROUBLESHOOTING CHART

| SYMPTOM | PROBABLE CAUSE | CORRECTIVE ACTION |
|---|---|---|
| All emergency lights inoperative when ac power is not available or cable W100 is disconnected. | <ul style="list-style-type: none"> a. Override toggle switch in OFF position. b. Loose or broken connectors or cables on 12 Vdc power supply. c. Relay switch stuck in charge position. d. Battery discharged. | <ul style="list-style-type: none"> a. Place override toggle switch in ON position. b. Trace cables, locate fault, and repair or replace defective connector cable. c. Repair or replace relay switch. d. Charge or replace battery. |
| Emergency lights weak or they weaken in a few seconds when activated by removal of ac power supply. | <ul style="list-style-type: none"> a. Battery terminal connections corroded. b. Battery state of charge is low due to relay switch failing to close in charge position when ac power supply is available. c. Battery state of charge is low due to inoperative battery charger when ac power supply is available. d. Battery defective (internal short) and fails to hold charge. | <ul style="list-style-type: none"> a. Clean and tighten connections. b. Repair or replace relay switch. c. Repair or replace battery charger. d. Replace battery. |
| One emergency light inoperative while other emergency lights operate. | <ul style="list-style-type: none"> a. Defective cable connector or cable to light. b. Defective lamp (bulb). | <ul style="list-style-type: none"> a. Trace cable, locate fault, and repair or replace defective connector or cable. b. Replace defective lamp. |

CHAPTER 6

FUNCTIONING OF EQUIPMENT

6-1 GENERAL. The functioning of the individual equipments in the OUTS subsystems, except for the Emergency Lighting Subsystem, is described in the following technical manuals.

6-2 POWER DISTRIBUTION SUBSYSTEM. For functioning of the Power Distribution Subsystem equipments, refer to TM 32-9999-200-15-1.

6-3 ANTENNA DISTRIBUTION SUBSYSTEM. For functioning of the Antenna Distribution Subsystem equipments, refer to TM 32-5895-753-14.

6-4 DIGITAL CLOCK SUBSYSTEM. For functioning of the Digital Clock Subsystem equipments, refer to TM 32-4940-200-14.

6-5 INTERCOMMUNICATION SUBSYSTEM. For functioning of the Intercommunication Subsystem equipments, refer to TM 32-5895-227-14.

6-6 EMERGENCY LIGHTING SUBSYSTEM. The function of the Emergency Lighting Subsystem is to provide sufficient illumination within the 21 shelters to enable the operators to evacuate the shelters in the event regular ac power is lost. The functioning of the equipment is shown in figure 6-1.

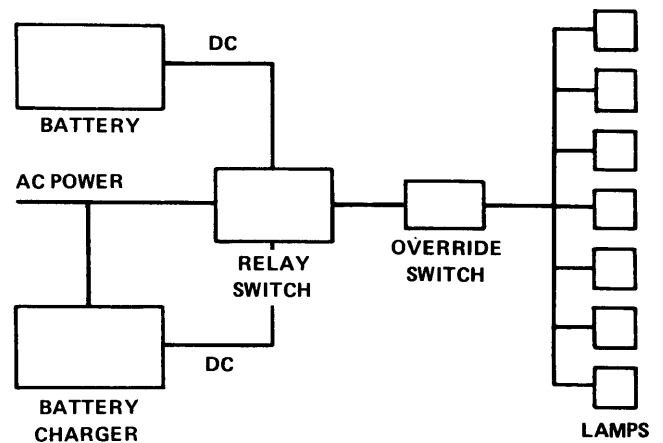

Figure 6-1. Emergency Lighting Block Diagram

a. A 100-A, 12-V, lead-acid storage battery is the emergency power source.

b. A relay switch connects the battery to the battery charger when ac power is available, and connects the battery to the lines for the lamps whenever ac power fails.

c. A 10-A battery charger maintains the battery in a charged state.

d. An override toggle switch provides for disconnecting the battery power from the lamps when emergency lighting is not needed and ac power is not available.

e. Seven remote lamps are mounted in the shelters and are directed to provide illumination in all shelters.

CHAPTER 7

DIRECT SUPPORT AND GENERAL SUPPORT MAINTENANCE INSTRUCTIONS

Section I. GENERAL

7-1 VOLTAGE AND RESISTANCE MEASUREMENTS.

When measuring voltages, use tape or sleeving (spaghetti) to insulate the entire test prod, except for its extreme tip. A momentary short can ruin a transistor. Make voltage and resistance measurements as directed, using the same or equivalent multimeter specified.

CAUTION

Do not use the ohmmeter with an open-circuit voltage exceeding 1.5 volts because transistors may be damaged.

a. Before using any ohmmeter to test transistors, check the open-circuit voltage across the ohmmeter test leads.

b. Use a coupling capacitor to connect test equipment (other than multimeter or VTVM) to transistorized circuits, to prevent damage to transistors.

c. If power supplies, other than those included in the system, are used to supply operating power, they must have good voltage regulation with low ac ripple. Otherwise, ripple spikes may exceed the maximum voltage rating of the transistors.

7-2 SCOPE OF DIRECT SUPPORT AND GENERAL SUPPORT MAINTENANCE. The direct support and general support maintenance procedures are not complete in themselves; they supplement the procedures at the organizational level, and include any additional techniques required to perform maintenance on the OUTS.

Section II. TOOLS AND EQUIPMENT

7-3 GENERAL. No special tools or equipment are authorized or required for maintenance of the OUTS. Refer to the applicable technical manuals listed in

Appendix A for special tools or equipment that may be required for specific items of equipment comprising the OUTS.

APPENDIX A**REFERENCES**

| | |
|----------------------|--|
| DA PAM 310-4 | Index of Technical Manuals, Technical Bulletins, Supply Manuals (types 7, 8 and 9), Supply Bulletins, and Lubrication Orders. |
| DA PAM 310-6 | Index of Supply Catalogs and Supply Manuals (Excluding types 7, 8 and 9). |
| DA PAM 310-7 | U.S. Army Equipment Index of Modification Work Orders. |
| TM 32-5410-217-14&P | Operator's, Organizational, Direct Support, and General Support Maintenance Manual (Including Repair Parts and Special Tools List) for Shelter, Electrical Equipment, S-389/MSA-34. |
| TM 32-5895-006-14&P | Operator's, Organizational, Direct Support, and General Support Maintenance Manual for Communications Central AN/TSC-75A. (To be published) |
| TM 32-4940-200-14 | Operator's, Organizational, Direct Support, and General Support Maintenance Manual for Teletype Maintenance Central AN/TGM-2 and Radio Maintenance Central AN/TRM-18. |
| TM 32-4940-200-15P | Operator's, Organizational, Direct Support, General Support, and Depot Maintenance Repair Parts and Special Tools Lists for Teletype Maintenance Central AN/TGM-2 and Radio Maintenance Central AN/TRM-18. |
| TM 32-4940-202-14 | Operator's, Organizational, Direct Support, and General Support Maintenance Manual for Administrative Control Central AN/TSQ-79. |
| TM 32-4940-202-15P | Operator's, Organizational, Direct Support, General Support, and Depot Maintenance Repair Parts and Special Tools Lists for Administrative Control Central AN/TSQ-79. |
| TM 32-5410-215-14 &P | Operator's, Organizational, Direct Support, and General Support Maintenance Manual for Repair Parts Storage Facility, AN/USM-379. |
| TM 32-5815-205-14 | Operator's, Organizational, Direct Support, and General Support Maintenance Manual for Facsimile Receiving Central AN/TXR-3. |
| TM 32-5815-205-15P | Operator's, Organizational, Direct Support, General Support, and Depot Maintenance Repair Parts and Special Tools Lists for Facsimile Receiving Central AN/TXR-3. |
| TM 32-5815-206-14 | Operator's, Organizational, Direct Support, and General Support Maintenance Manual for Teletype Receiving Centrals AN/TGR-1 and AN/TGR-2. |
| TM 32-5815-206-15P | Operator's, Organizational, Direct Support, General Support, and Depot Maintenance Repair Parts and Special Tools Lists for Teletype Receiving Centrals AN/TGR-1 and AN/TGR-2. |
| TM 32-5985-205-15 | Operator's, Organizational, Direct Support, General Support, and Depot Maintenance Manual Antenna System AN/MRA-17. |

APPENDIX A (Continued)

| | |
|---------------------|--|
| TM 32-5895-216-14 | Operator's, Organizational, Direct Support, and General Support Maintenance Manual for Operations Control Central AN/TSQ-78. |
| TM 32-5895-216-15P | Operator's, Organizational, Direct Support, General Support, and Depot Maintenance Repair Parts and Special Tools Lists for Operations Control Central AN/TSQ-78. |
| TM 32-5895-217-14 | Operator's, Organizational, Direct Support, and General Support Maintenance Manual for Radio Receiver Central AN/TRR-27. |
| TM 32-5895-217-15P | Operator's, Organizational, Direct Support, General Support, and Depot Maintenance Repair Parts and Special Tools Lists for Radio Receiver Central AN/TRR-27. |
| TM 32-5895-218-14 | Operator's, Organizational, Direct Support, and General Support, Maintenance Manual for Radio Identification Central AN/TRX-1. |
| TM 32-5895-218-15P | Operator's, Organizational, Direct Support, General Support, and Depot Maintenance Repair Parts and Special Tools Lists for Radio Identification Central AN/TRX-1. |
| TM 32-5895-227-14 | Instruction Manual for Communications Central AN/MSQ-71. |
| TM 32-5895-248-15P | Operator's, Organizational, Direct Support, General Support, and Depot Maintenance Repair Parts and Special Tools Lists for Data Analysis Central AN/TYQ-5. |
| TM 32-5895-248-14 | Operator's, Organizational, Direct Support, and General Support Maintenance Manual for Data Analysis Central AN/TYQ-5. |
| TM 32-9999-200-15-1 | Operator's, Organizational, Direct Support, General Support, and Depot Maintenance Manual (Including Repair Parts Lists) for Operations and Electrical Facility, Mobile AN/MSA-34 (Serial Numbers 1 through 15). |
| TM 32-9999-200-15-2 | Operator's, Organizational, Direct Support, General Support, and Depot Maintenance Manual, with Consolidated Repair Parts and Special Tools Lists for V-398/MSA-34 Semitrailer Low Bed. |
| TM 38-750 | The Army Maintenance Management System (TAMMS). |
| TM 740-90-1 | Administrative Storage of Equipment. |
| TM 750-244-2 | Procedures for the Destruction of Electronics Materiel to Prevent Enemy Use (Electronics Command). |

APPENDIX B

MAINTENANCE ALLOCATION CHART

Section I. INTRODUCTION

B-1 GENERAL

a. This section provides a general explanation of all maintenance and repair functions authorized at various maintenance levels.

b. The Maintenance Allocation Chart (MAC) in section II designates overall responsibility for the performance of maintenance functions on the identified end item or component. The implementation of the maintenance functions upon the end item or component will be consistent with the assigned maintenance functions.

c. Section III lists the tool and test equipment required for a particular maintenance function as referenced from section II.

d. Section IV contains supplemental instructions on explanatory notes for a particular maintenance function as referenced from section II.

B-2 MAINTENANCE FUNCTIONS

a. Inspect. To determine the serviceability of an item by comparing its physical, mechanical and/or electrical characteristics with established standards through examination.

b. Test. To verify serviceability and detect incipient failure by measuring the mechanical or electrical characteristics of an item and comparing those characteristics with prescribed standards.

c. Service. Operations required periodically to keep an item in proper operating condition; i.e., to clean (decontaminate), to preserve, to drain, to paint, or to replenish fuel, lubricants, hydraulic fluids, or compressed air supplies.

d. Adjust. To maintain, within prescribed limits, by bringing into proper or exact position, or by setting the operating characteristics to specified parameters.

e. Align. To adjust specified variable elements of an item to bring about optimum or desired performance.

f. Calibrate. To determine and cause corrections to be made or to be adjusted on instruments or test measuring and diagnostic equipments used in precision measurement. Consists of comparisons of two instruments, one of which is a certified standard of known accuracy, to detect and adjust any discrepancy in the accuracy of the instrument being compared.

g. Install. The act of emplacing, seating, or fixing into position an item, part, or module (component or assembly) in a manner to allow the proper functioning of an equipment or system.

h. Replace. The act of substituting a serviceable like type part, subassembly, or module (component or assembly) for an unserviceable counterpart.

i. Repair. The application of maintenance services or other maintenance actions to restore serviceability to an item by correcting specific damage, fault, malfunction, or failure in a part, subassembly, module (component or assembly), and item, or system.

j. Overhaul. That maintenance effort (services/actions) necessary to restore an item to a completely serviceable/operational condition as prescribed by maintenance standards; i.e., DMWR, in appropriate technical publications. Overhaul is normally the highest degree of maintenance performed by the Army. Overhaul does not normally return an item to like new condition.

k. Rebuild. Consists of those services/actions necessary for the restoration of unserviceable equipment to a like new condition in accordance with original manufacturing standards. Rebuild is the highest degree of materiel maintenance applied to Army equipment. The rebuild operation includes the act of returning to zero those age measurements (hours/miles, etc.) considered in classifying Army equipments/components.

B-3 COLUMN ENTRIES USED IN THE MAC

a. Column 1, Group Number. Column 1 lists group numbers, the purpose of which is to identify components, assemblies, subassemblies, and modules with the next higher assembly.

b. Column 2, Component/Assembly. Column 2 contains the names of components, assemblies, subassemblies, and modules for which maintenance is authorized.

c. Column 3, Maintenance Functions. Column 3 lists the functions to be performed on the item listed in column 2. (For detailed explanation of these functions, see paragraph B-2.)

d. Column 4, Maintenance Level. Column 4 specifies, by the listing of a “work time” figure in the appropriate sub-column(s), the lowest level of maintenance authorized to perform the function listed in column 3. This figure represents the active time required to perform the maintenance function at the indicated level of maintenance. If the number or complexity of the tasks within the listed maintenance function vary at different maintenance levels, appropriate “work time” figures will be shown for each level. The number of man-hours specified by the “work time” figure represents the average time required to restore an item (assembly, subassembly, component, module, end item, or system) to a serviceable condition under typical field operating conditions. This time includes preparation time, troubleshooting time, and quality assurance/quality control time in addition to the time required to perform the specific tasks identified for the maintenance functions authorized in the maintenance allocation chart. The symbol designations for the various maintenance levels are as follows:

- C Operator or crew.
- O Organization maintenance.
- F Direct support maintenance.
- H General support maintenance.
- D Depot maintenance.

e. Column 5, Tools and Equipment. Column 5 specifies, by code, those common tool sets (not individual tools) and

special tools, test, and support equipment required to perform the designated function.

f. Column 6, Remarks. Column 6 contains letter codes in alphabetical order which shall be keyed to the remarks contained in section IV.

B-4 COLUMN ENTRIES USED IN TOOL AND TEST EQUIPMENT REQUIREMENTS

a. Column 1, Tool or Test Equipment Reference Code. The tool and test equipment reference code correlates with a maintenance function on the identified end item or component.

b. Column 2, Maintenance Level. The lowest level of maintenance authorized to use the tool or test equipment.

c. Column 3, Nomenclature. Name or identification of the tool or test equipment.

d. Column 4, National/NATO Stock Number. The National or NATO stock number of the tool or test equipment.

e. Column 5, Tool Number. The manufacturer’s part number.

B-5 EXPLANATION OF COLUMNS IN SECTION IV.

a. Reference Code. The code scheme recorded in column 6, section II.

b. Remarks. This column lists information pertinent to the maintenance function being performed as indicated on the MAC, section II.

Section II. MAINTENANCE ALLOCATION CHART

| (1) Group Number | (2) Component/Assembly | (3) Maintenance function | (4) Maintenance level | | | | | (5) Tools and equipment | (6) Remarks |
|------------------------|---|---|--------------------------|--------------------------|---|---|---|-------------------------------|----------------|
| | | | C | O | F | H | D | | |
| 00 | Operation 1 Unit, Transportable System | Inspect Service Install | | 0.5 0.5 40.0 | | | | | |
| 01 | Repair Parts Storage Facility AN/USM-379 | Inspect Install Replace Repair | | 0.3 2.0 2.0 2.0 | | | | | |
| 02 | Radio Maintenance Central AN/TRM-18 | Inspect Install Replace Repair | | 0.3 2.0 2.0 2.0 | | | | A | |
| 03 | Radio Receiver Central AN/TRR-27 | Inspect Install Replace Repair | | 0.3 2.0 2.0 2.0 | | | | B | |
| 04 | Teletype Maintenance Central AN/TGM-2 | Inspect Install Replace Repair | | 0.3 2.0 2.0 2.0 | | | | A | |
| 05 | Teletype Receiving Central AN/TGR-2 | Inspect Install Replace Repair | | 0.3 2.0 2.0 2.0 | | | | C | |
| 06 | Facsimile Receiving Central AN/TXR-3 | Inspect Install Replace Repair | | 0.3 2.0 2.0 2.0 | | | | D | |
| 07 | Administrative Control Central AN/TSQ-79 | Inspect Install Replace Repair | | 0.3 2.0 2.0 2.0 | | | | E | |
| 08 | Teletype Receiving Central AN/TGR-1 | Inspect Install Replace Repair | | 0.3 2.0 2.0 2.0 | | | | C | |
| 09 | Data Analysis Central AN/TYQ-5 | Inspect Install Replace Repair | | 0.3 2.0 2.0 2.0 | | | | F | |
| 10 | Communications Central AN/TSC-75A | Inspect Install Replace Repair | | 0.3 2.0 2.0 2.0 | | | | G | |
| 11 | Operations Control Central AN/TSQ-78 | Inspect Install Replace Repair | | 0.3 2.0 2.0 2.0 | | | | H | |

Section II. MAINTENANCE ALLOCATION CHART

| (1) Group Number | (2) Component/Assembly | (3) Maintenance function | (4) Maintenance level | | | | | (5) Tools and equipment | (6) Remarks |
|------------------------|---|--|--------------------------|---------------------------------|------------|---|-------------|-------------------------------|----------------|
| | | | C | O | F | H | D | | |
| 12 | Radio Identification Central AN/TRX- 1 | Inspect Install Replace Repair | | 0.3 2.0 2.0 2.0 | | | | | I |
| 13 | V-398/MSA Semitrailer, Low Bed | Inspect Install Replace Repair | | 0.3 2.0 2.0 2.0 | | | | | J |
| 14 | Cable Group | | | | | | | | |
| 1401 | Cables, RF Antenna Distribution | Inspect Service Replace Repair | 0.3 0.3 | | 0.5 0.8 | | | | H |
| 1402 | Cables, Digital Clock | Inspect Service Replace Repair | 0.3 0.3 | | 0.5 0.8 | | 1 | | B |
| 1403 | Cables, Intercom | Inspect Service Replace Repair | 0.3 0.3 | | 0.5 0.8 | | 1 | | H |
| 1404 | Cables, Emergency Lighting | Inspect Service Replace Repair | 0.3 0.3 | | 0.5 0.8 | | 1 | | |
| 15 | Power Source Assy, Emergency Lighting | Inspect Test Service Replace Repair | | 0.3 0.3 0.3 0.8 0.8 | | | 2 1 1 | | |
| 16 | Walkway | Inspect Service Install Replace Repair | 0.2 | 0.3 0.8 0.8 0.8 | | | 1 1 1 | | |

Section III. TOOL AND TEST EQUIPMENT REQUIREMENTS

| (1) Reference code | (2) Maintenance level | (3) Nomenclature | (4) National/NATO stock number | (5) Tool number |
|-----------------------------------|--------------------------------------|-----------------------------|---|--------------------------------|
| 1 | 0 | Tool Kit TK-105-G | 5180-00-610-8177 | |
| 2 | 0 | Multimeter AN/USM-223 | 6625-00-999-7465 | |

Section IV. REMARKS

| Reference code | Remarks |
|----------------|---|
| A | Refer to TM 32-4940-200-14 and -15P for maintenance instructions and parts. |
| B | Refer to TM 32-5895-217-14 and -15P for maintenance instructions and parts. |
| C | Refer to TM 32-5815-206-14 and -15P for maintenance instructions and parts. |
| D | Refer to TM 32-5815-205-14 and -15P for maintenance instructions and parts. |
| E | Refer to TM 32-4940-202-14 and -15P for maintenance instructions and parts. |
| F | Refer to TM 32-5895-248-14 and -15P for maintenance instructions and parts. |
| G | Refer to TM 32-5895-006-14 and -15P for maintenance instructions and parts. |
| H | Refer to TM 32-5895-216-14 and -15P for maintenance instructions and parts. |
| I | Refer to TM 32-5895-218-14 and -15P for maintenance instructions and parts. |
| J | Refer to TM 32-9999-200-15 for maintenance instructions and parts. |

By Order of the Secretary of the Army:

Official:

PAUL T. SMITH

Major General, United States Army
The Adjutant General

BERNARD W. ROGERS
General, United States Army
Chief of Staff

RECOMMENDED CHANGES TO EQUIPMENT TECHNICAL PUBLICATIONS



THEN...JOT DOWN THE DOPE ABOUT IT ON THIS FORM. CAREFULLY TEAR IT OUT, FOLD IT AND DROP IT IN THE MAIL.

SOMETHING WRONG WITH PUBLICATION

FROM: (PRINT YOUR UNIT'S COMPLETE ADDRESS)

DATE SENT

PUBLICATION NUMBER

PUBLICATION DATE

PUBLICATION TITLE

BE EXACT PIN-POINT WHERE IT IS

PAGE NO.

PARA-GRAPH

FIGURE NO.

TABLE NO.

IN THIS SPACE, TELL WHAT IS WRONG AND WHAT SHOULD BE DONE ABOUT IT.

TEAR ALONG PERFORATED LINE

PRINTED NAME, GRADE OR TITLE AND TELEPHONE NUMBER

SIGN HERE

The Metric System and Equivalents

Linear Measure

1 centimeter = 10 millimeters = .39 inch
 1 decimeter = 10 centimeters = 3.94 inches
 1 meter = 10 decimeters = 39.37 inches
 1 dekameter = 10 meters = 32.8 feet
 1 hectometer = 10 dekameters = 328.08 feet
 1 kilometer = 10 hectometers = 3,280.8 feet

Weights

1 centigram = 10 milligrams = .15 grain
 1 decigram = 10 centigrams = 1.54 grains
 1 gram = 10 decigrams = .035 ounce
 1 dekagram = 10 grams = .35 ounce
 1 hectogram = 10 dekagrams = 3.52 ounces
 1 kilogram = 10 hectograms = 2.2 pounds
 1 quintal = 100 kilograms = 220.46 pounds
 1 metric ton = 10 quintals = 1.1 short tons

Liquid Measure

1 centiliter = 10 milliliters = .34 fl. ounce
 1 deciliter = 10 centiliters = 3.38 fl. ounces
 1 liter = 10 deciliters = 33.81 fl. ounces
 1 dekaliter = 10 liters = 2.64 gallons
 1 hectoliter = 10 dekaliters = 26.42 gallons
 1 kiloliter = 10 hectoliters = 264.18 gallons

Square Measure

1 sq. centimeter = 100 sq. millimeters = .155 sq. inch
 1 sq. decimeter = 100 sq. centimeters = 15.5 sq. inches
 1 sq. meter (centare) = 100 sq. decimeters = 10.76 sq. feet
 1 sq. dekameter (are) = 100 sq. meters = 1,076.4 sq. feet
 1 sq. hectometer (hectare) = 100 sq. dekameters = 2.47 acres
 1 sq. kilometer = 100 sq. hectometers = .386 sq. mile

Cubic Measure

1 cu. centimeter = 1000 cu. millimeters = .06 cu. inch
 1 cu. decimeter = 1000 cu. centimeters = 61.02 cu. inches
 1 cu. meter = 1000 cu. decimeters = 35.31 cu. feet

Approximate Conversion Factors

| To change | To | Multiply by | To change | To | Multiply by |
|---------------|--------------------|-------------|--------------------|---------------|-------------|
| inches | centimeters | 2.540 | ounce-inches | newton-meters | .007062 |
| feet | meters | .305 | centimeters | inches | .394 |
| yards | meters | .914 | meters | feet | 3.280 |
| miles | kilometers | 1.609 | meters | yards | 1.094 |
| square inches | square centimeters | 6.451 | kilometers | miles | .621 |
| square feet | square meters | .093 | square centimeters | square inches | .155 |
| square yards | square meters | .836 | square meters | square feet | 10.764 |
| square miles | square kilometers | 2.590 | square meters | square yards | 1.196 |
| acres | square hectometers | .405 | square kilometers | square miles | .386 |
| cubic feet | cubic meters | .028 | square hectometers | acres | 2.471 |
| cubic yards | cubic meters | .765 | cubic meters | cubic feet | 35.315 |
| fluid ounces | milliliters | 29.573 | cubic meters | cubic yards | 1.308 |
| pints | liters | .473 | milliliters | fluid ounces | .034 |
| quarts | liters | .946 | liters | pints | 2.113 |
| gallons | liters | 3.785 | liters | quarts | 1.057 |
| ounces | grams | 28.349 | liters | gallons | .264 |
| pounds | kilograms | .454 | grams | ounces | .035 |
| short tons | metric tons | .907 | kilograms | pounds | 2.205 |
| pound-feet | newton-meters | 1.356 | metric tons | short tons | 1.102 |
| pound-inches | newton-meters | .11296 | | | |

Temperature (Exact)

°F Fahrenheit temperature 5/9 (after subtracting 32) Celsius temperature °C

PIN: 017912-000